

**BIDDING DOCUMENTS**

**FOR**

**PROCUREMENT OF WORKS**  
**(ELECTRICAL & MECHANICAL)**



*Office of* **THE EXECUTIVE ENGINEER**  
**SWABI IRRIGATION DIVISION-II SWABI**  
Phone / Fax: 0938-920031 Email: [xen2swabi@yahoo.com](mailto:xen2swabi@yahoo.com)

---

**SWABI IRRIGATION DIVISION-II SWABI**

TABLE OF CONTENTS

**INVITATION FOR BIDS** .....

**INSTRUCTIONS TO BIDDERS**.....

**BIDDING DATA**.....

**ANNEXURE TO BIDDING DATA** .....

**LETTER OF BID AND APPENDICES TO BID**.....

**STANDARD FORMS** .....

**CONDITIONS OF CONTRACT** .....

**GENERAL CONDITIONS (GC)** .....

**PARTICULAR CONDITIONS (PC)** .....

**Part-A Contract Data** .....

**Part-B Specific Provisions** .....

**SPECIFICATIONS - SPECIAL PROVISIONS**

**SPECIFICATIONS - TECHNICAL PROVISIONS** .....

**DRAWINGS**

# **INVITATION FOR BIDS**

**IRRIGATION DEPARTMENT  
NOTICE INVITING RE E-BIDDING  
SINGLE STAGE SINGLE ENVELOPE**

Irrigation Department (Swabi Irrigation Division-II Swabi) Govt. of Khyber Pakhtunkhwa invites electronic bids from the eligible firms of Irrigation Department in accordance with KPPRA procurement prevailing rules 2014 alongwith uptodate amendments, on **Single Stage single Envelop System** who have renewed their registration / License with Provincial Works Department Khyber Pakhtunkhwa and Pakistan Engineering Council in relevant category with relevant field of specialization for the Year 2021-22 through E-Bidding System.

S#	Work Name	E/cost	Earnest Money (Rs.)	Required PEC field of specialization
A	<b>ADP No.2359 /180617</b> Construction of Flood Protection works Irrigation Channels and installation of solar Tubewells in Khyber Pakhtunkhwa on need basis			
1	Supply and installation of solar system pumping machinery alongwith all accessories for 02 No Irrigation Tubewells in Hund areas, District Swabi	8.992	1.7984	EE-11 EE-04 CE-09
2	Supply and installation of solar system pumping machinery alongwith all accessories for 2 No Irrigation T/Wells in village Daulat and Dobian areas Distt Swabi	7.72	1.544	---do---
B	<b>ADP No.1242/140537</b> Provision of Irrigation Augmentation Tubewells and lift Irrigation Schemes on need basis in Khyber Pakhtunkhwa			
3	Supply and installation of solar system pumping machinery alongwith all accessories for 1 No Irrigation / augmentation T/Wells in PK-33 District Swabi.	4.11	0.0822	EE-11 EE-04 CE-09

**TERMS / CONDITIONS:-**

1. Bid Solicitation documents including Instructions to Bidders can be downloaded from Irrigation website <http://www.irrigation.gkp.pk/> as well as KPPRA website otherwise bids submitted without these documents (duly filled) will be considered non-responsive.
2. Bid Solicitation Documents issued to the bidders contains requirements for eligible bidders and other important terms and conditions.
3. Electronic Bidding shall be done on “**above / below system**” on BOQ/Engineer estimate, based on the MRS/NSI where applicable. Only two digits after the decimal point shall be considered for evaluation purpose.
4. The Employer has the authority to reject any bid or all the bids assigning cogent reasons.
5. Bid security of the 1st, 2nd and 3rd lowest Electronic Bidder for the specific work will be retained by the Department for one week after issuance of letter of acceptance to the successful bidder.
6. The exemption information in the BOQ shall be provided complete in all respect supported by evidence of exemption otherwise the bid shall be declared Non-responsive KPPRA S.R.O (10) / Vol:1-18/2020-21/2785-98 dated 10/02/2021.
7. All the bidders / Firms must be register with the Khyber Pakhtunkhwa Revenue Authority.
8. All the prevailing KPPRA Acts / rules updated instruction/ notifications and other government notifications will be applicable issued from time to time.
9. Pre-bid meeting will be held on 04.4.2022 at 11.00 AM in the office of Executive Engineer, Swabi Irrigation Division-II Swabi.

10. The last date for bid submission is 12.4.2022 @ 12.00 PM which will be opened on 12.4.2022 at 12.30 PM in the office of the undersigned in front of Contractors and their representatives who wish to attend.

EXECUTIVE ENGINEER  
SWABI IRRIGATION DIVISION-II  
SWABI.  
Phone & Fax # 0938-920031  
E-mail: xen2swabi@yahoo.com

# **BILL OF QUANTITIES**

**BILL OF QUANTITY**

NAME OF WORK:- CONSTRUCTION OF FLOOD PROTECTION WORKS, IRRIGATION CHANNELS AND INSTALLATION OF SOLAR TUBE WELLS IN KHYBER PAKHTUNKHWA ON NEED BASIS. (ADP # 2359/ 180617) 2020-2021.						
SUB WORK:- Supply and Installation of Solar system Pumping Machinery along with all accessories for 02 Nos Irrigation TubeWell at Hund Area Distt: Swabi						
		Estimated Cost Rs, 8.89 (M)				
		Date of Tender 12.4.2022				
S.#	MRS 2020	Description of Item	Qty	Unit	Rate	Amount
1	(26-01-r)	Supply and erection of PV mounting frame with manual trakering..	21	PKW	29276.46	614805.66
2	26-01-i-03-c)	Supply and Erection of GRID TIE INVERTER (ON-Grid Inverter) (20-30 KW) .	25377	P.Wait	22.09	560577.93
3	(26-01-d-01	Supply and erection of solar PV Module ( Solar Panel) Mono - Crstalline A-Grade ( per watt) ( as per approved specifications)	25377	P.Wait	72.58	1841862.66
4	24-50-a-03	Supply & Installation, testing and commissioning of Submersible Pump (ISO – 9906 Certified) Coupled with Submersible rewind-able Electric Motor with AC winding and all ccessories like Motor Control Unit (equipped with UV/OV, dry run protection device, surge protection, phase reverse indicator) Complete in all accessories including NRV, Pressure Gauge, Sluice valve except column pipe and power cable with appropriate Head and Discharge : 25 HP	1.00	No	454872.41	454872.41
5	24-56-a	Supply and Fixing MS Column pipe with flanges for sub,erssible pump : 4" ( 100 mm) Nominal Pipe Size PS), 3/16" thick, 10' length .	145.30	M	2901.66	421611.20
6	(24-50-c-01	Supply and installation of submersible flat cable made of 99.9% pper, coated with double PVC as per BSS Standards, 3 x 10 mm2	68.00	M	635.75	43231.00
7	26-01-g-03	Supply and erection 1x6 sq.mm single core (XPLE/XPLO sulated/PCV sheathed) flexible copper cable.	65.00	M	228.03	14821.95
8	(26-01-g-04	Supply and erection 1x10 sq.mm flexible copper cable.	68.00	M	349.84	23789.12
9	market Rate	Supply/Fixing of AC 3 phase circuit bracker best quality. (32 to 60 amp) Market Rate	1.00	No	8000.00	8000.00
10	market Rate	Supply/Fixing of AC and DC connection boxes fues earthing system PVC pipe, earth wire etc (as per site requirement) Market Rate	1.000	job	30000.00	30000.00
11	24-38-f	Supplying and Fixing Flanged Expansion Joints BSS 2035: 6" i/d	1.00	No	10680.88	10680.88
12	market Rate	Supply and Fixing bore cover plate cover (2 pice) clamp 3/8" thickarrangement holes for column and Cable ,hole 1"1/c for inspection of water levelin tube well (Market Rate)	1.00	No	1787.00	1787.00
13	market Rate	Supply and Fixing of stand for solar panel on pump house (market Rate)	3.00	No	4000.00	12000.00
14	market Rate	Supply and Fixing of battery stand including battery terminal wire and	2.00	P.No	6000.00	12000.00

		connection box complete job.(market Rate) (market Rate)				
15	26-01-C-06	Supply and erection of AC /Dc energy efficient LED Light bulbs (16-20 W)	4.00	P.No	869.36	3477.44
16	15-45	Wiring of light /fan /call bell point in 3/0.029 pvc insulated & sheated cable on shal wood strip.	6.00	No	843.67	5062.02
17	(26-01-f-02	Supply and erection of 12v VRLA AGM Battery (15 AH 12W)	150.00	P.Job	293.60	44040.00
18	03-25-b-	Excavation in foundation of building bridges etc complete in ordinary soil	826.65 0	M3	243.91	201628.20
19	06-03-b	Cement concrete (brick /stone ballast 1.5" to 2" nullah shingle well graded and cleaned)in foundation and plinth (Ratio 1:4:8)	1.1607	M3	4663.21	5412.59
20	06-07-b-03	RCC in Raft foundation base slab,of column & ret: wall etc not including in (06-06)(Ratio 1:2:4)	5.662	M3	9203.68	52111.24
21	06-08-c	Supply and fabrication M.S Reinforcement for cement concrete (Hot rolled deformrd bars grade 40)	0.3910 71	M3	141789.8	55449.88
22	28-17*b	Providing and fixing barbed wire fencing with 4 horizontal & 2 crass wires with P.c.c 1:4:8 base 12"x12"x21"	33.53	M	1762.96	59105.00
23	Market Rate	Providing and installation of angle iron gate size 6x8 angle iron size 2"x2"x3/16" and barbed wire fix 6"x6" sq with locking system complete including fixing charges (as direction of engineer/ingineer (Market Rate)	4.4592	M2	3767.70	16800.93
24	Market Rate	Supply and fixing of indenfication boar size 18 gauge sheet 18"x18" painted writing of tube well no etc i/c fixing at site. (Market Rate).	1.00	P.Job	3000.00	3000.00
						4496127.1 1
		ADD: for One No More	2.00	P.Job	4496127.10	8992254.19



**BILL OF QUANTITY**

NAME OF WORK:- CONSTRUCTION OF FLOOD PROTECTION WORKS, IRRIGATION CHANNELS AND INSTALLATION OF SOLAR TUBE WELLS IN KHYBER PAKHTUNKHWA ON NEED BASIS. (ADP # 2359/ 180617) 2020-2021.						
SUB WORK:- Supply and Installation of Solar system Pumping Machinery along with all accessories for 02 Nos Irrigation TubeWell at village Daulat and Dobian area District Swabi.						
		Estimated Cost Rs, 7.71 (M)				
		Date of Tender 12.4.2022				
S.#	MRS 2020	Description of Item	Qty	Unit	Rate	Amount
1	(26-01-r)	Supply and erection of PV mounting frame with manual trakering..	41.05	PKW	29276.46	1201798.683
2	26-01-i-03-c)	Supply and Erection of GRID TIE INVERTER (ON-Grid Inverter) (20-30 KW) .	41056	P.Wait	22.09	906927.04
3	(26-01-d-01	Supply and erection of solar PV Module ( Solar Panel) Mono - Crstalline A-Grade ( per watt) ( as per approved specifications)	41056	P.Wait	72.58	2979844.48
4	24-50-a-03	Supply & Installation, testing and commissioning of Submersible Pump (ISO – 9906 Certified) Coupled with Submersible rewind-able Electric Motor with AC winding and all ccessories like Motor Control Unit (equipped with UV/OV, dry run protection device, surge protection, phase reverse indicator) Complete in all accessories including NRV, Pressure Gauge, Sluice valve except column pipe and power cable with appropriate Head and Discharge : 25 HP	2.00	No	454872.41	909744.82
5	24-56-a	Supply and Fixing MS Column pipe with flanges for sub,erssible pump : 4" ( 100 mm) Nominal Pipe Size PS), 3/16" thick, 10' length .	304.78	M	2901.66	884367.93
6	(24-50-c-01	Supply and installation of submersible flat cable made of 99.9% pper, coated with double PVC as per BSS Standards, 3 x 10 mm2	152.00	M	635.75	96634.00
7	26-01-g-03	Supply and erection 1x6 sq.mm single core (XPLE/XPLO sulated/PCV sheathed) flexible copper cable.	152.00	M	228.03	34660.56
8	(26-01-g-04	Supply and erection 1x10 sq.mm flexible copper cable.	152.00	M	349.84	53175.68
9	market Rate	Supply/Fixing of AC 3 phase circuit bracker best quality. (32 to 60 amp) Market Rate	2.00	No	8000.00	16000.00
10	market Rate	Supply/Fixing of AC and DC connection boxes fues earthing system PVC pipe, earth wire etc (as per site requirement) Market Rate	2.000	job	30000.00	60000.00
11	24-38-f	Supplying and Fixing Flanged Expansion Joints BSS 2035: 6" i/d	2.00	No	10680.88	21361.76
12	market Rate	Supply and Fixing bore cover plate cover (2 pice) clamp 3/8" thickarrangement holes for column and Cable ,hole 1"1/c for inspection of water levelin tube well (Market Rate)	2.00	No	1787.00	3574.00
12	market Rate	Supply and Fixing of stand for solar panel on pump house (market Rate)	6.00	No	4000.00	24000.00
14	market Rate	Supply and Fixing of battery stand including battery terminal wire and connection box complete job.(market	4.00	P.No	6000.00	24000.00

		Rate) (market Rate)				
15	26-01-C-06	Supply and erection of AC /Dc energy efficient LED Light bulbs (16-20 W)	8.00	P.No	869.36	6954.88
16	15-45	Wiring of light /fan /call bell point in 3/0.029 pvc insulated & sheated cable on shal wood strip.	12.00	No	843.67	10124.04
17	(26-01-f-02	Supply and erection of 12v VRLA AGM Battery (15 AH 12W)	300.00	P.Job	293.60	88080.00
18	03-25-b-	Excavation in foundation of building bridges etc complete in ordinary soil	16.54	M3	243.91	4034.27
19	06-03-b	Cement concrete (brick /stone ballast 1.5" to 2" nullah shingle well graded and cleaned)in foundation and plinth (Ratio 1:4:8)	2.32	M3	4663.21	10818.65
20	06-07-b-03	RCC in Raft foundation base slab,of column & ret: wall etc not including in (06-06)(Ratio 1:2:4)	11.20	M3	9203.68	103081.22
21	06-08-c	Supply and fabrication M.S Reinforcement for cement concrete (Hot rolled deformrd bars grade 40)	0.80	M3	141789.8	113431.84
22	28-17*b	Providing and fixing barbed wire fencing with 4 horizontal & 2 crass wires with P.c.c 1:4:8 base 12"x12"x21"	67.06	M	1762.96	118224.10
23	Market Rate	Providing and installation of angle iron gate size 6x8 angle iron size 2"x2"x3/16" and barbed wire fix 6"x6" sq with locking system complete including fixing charges (as direction of engineer/ingineer (Market Rate)	9.00	M2	3767.70	33909.30
24	Market Rate	Supply and fixing of indenfication boar size 18 gauge sheet 18"x18" painted writing of tube well no etc i/c fixing at site. (Market Rate).	2.00	P.Job	3000.00	6000.00
						7710747

**BILL OF QUANTITY**

NAME OF WORK:- PROVISION OF IRRIGATION AUGMENTATION TUBE WELL AND LIS ON NEED BASIS IN KHYBER PAKHTUNKHWA. ADP NO. 1242/140537						
SUB WORK:- Supply and Installation of Solar system Pumping Machinery along with all accessories for 01 No Irrigation TubeWell in PK-33 Swabi.						
		Estimated Cost Rs, 4.11 (M)				
		Date of Tender 12.4.2022				
S.No	MRS 2020	Description of Item	Qty	Unit	Rate	Amount
1	(26-01-r)	Supply and erection of PV mounting frame with manual tracking..	20.528	PKW	29276.46	600987.1709
2	26-01-i-03-c)	Supply and Erection of GRID TIE INVERTER (ON-Grid Inverter) (20-30 KW) .	20528	P.Wait	22.09	453463.52
3	(26-01-d-01	Supply and erection of solar PV Module ( Solar Panel) Mono - Crystalline A-Grade ( per watt) ( as per approved specifications)	22328	P.Wait	72.58	1620566.24
4	24-50-a-04	Supply & Installation, testing and commissioning of Submersible Pump (ISO – 9906 Certified) Coupled with Submersible rewind-able Electric Motor with AC winding and all accessories like Motor Control Unit (equipped with UV/OV, dry run protection device, surge protection, phase reverse indicator) Complete in all accessories including NRV, Pressure Gauge, Sluice valve except column pipe and power cable with appropriate Head and Discharge : 30 HP	1.00	No	508057.91	508057.91
5	24-56-a	Supply and Fixing MS Column pipe with flanges for submersible pump : 4" ( 100 mm) Nominal Pipe Size PS), 3/16" thick, 10' length .	152.39	M	2901.66	442183.97
6	(24-50-c-01	Supply and installation of submersible flat cable made of 99.9% pper, coated with double PVC as per BSS Standards, 3 x 10 mm2	100.00	M	635.75	63575.00
7	26-01-g-03	Supply and erection 1x6 sq.mm single core (XPLE/XPLO sulated/PCV sheathed) flexible copper cable.	100.00	M	228.03	22803.00
8	(26-01-g-04	Supply and erection 1x10 sq.mm flexible copper cable.	100.00	M	349.84	34984.00
9	market Rate	Supply/Fixing of AC 3 phase circuit bracker best quality. (32 to 60 amp) Market Rate	1.00	No	8000.00	8000.00
10	market Rate	Supply/Fixing of AC and DC connection boxes fues earthing system PVC pipe, earth wire etc (as per site requirement) Market Rate	1.000	job	30000.00	30000.00
11	24-38-f	Supplying and Fixing Flanged Expansion Joints BSS 2035: 6" i/d	1.00	No	10680.88	10680.88
12	market Rate	Supply and Fixing bore cover plate cover (2 pice) clamp 3/8" thick arrangement holes for column and Cable ,hole 1"1/c for inspection of water leveling tube well (Market Rate)	1.00	No	1787.00	1787.00
13	market Rate	Supply and Fixing of stand for solar panel on pump house (market Rate)	4.00	No	4000.00	16000.00
14	market Rate	Supply and Fixing of battery stand including battery terminal wire and connection box complete job.(market Rate) (market Rate)	3.00	P.No	6000.00	18000.00

15	26-01-C-06	Supply and erection of AC /Dc energy efficient LED Light bulbs (16-20 W)	6.00	P.No	869.36	5216.16
16	15-45	Wiring of light /fan /call bell point in 3/0.029 pvc insulated & sheeted cable on shal wood strip.	8.00	No	843.67	6749.36
17	(26-01-f-02	Supply and erection of 12v VRLA AGM Battery (15 AH 12W)	300.00	P.Job	293.60	88080.00
18	03-25-b-	Excavation in foundation of building bridges etc complete in ordinary soil	8.27	M3	243.91	2017.14
19	06-03-b	Cement concrete (brick /stone ballast 1.5" to 2" nullah shingle well graded and cleaned)in foundation and plinth (Ratio 1:4:8)	1.16	M3	4663.21	5409.32
20	06-07-b-03	RCC in Raft foundation base slab,of column & ret: wall etc not including in (06-06)(Ratio 1:2:4)	5.60	M3	9203.68	51540.61
21	06-08-c	Supply and fabrication M.S Reinforcement for cement concrete (Hot rolled deformed bars grade 40)	0.40	M3	141789.8	56715.92
22	28-17*b	Providing and fixing barbed wire fencing with 4 horizontal & 2 crass wires with P.c.c 1:4:8 base 12"x12"x21"	33.53	M	1762.96	59105.00
23	Market Rate	Providing and installation of angle iron gate size 6x8 angle iron size 2"x2"x3/16" and barbed wire fix 6"x6" sq with locking system complete including fixing charges (as direction of engineer/engineer (Market Rate)	4.50	M2	3767.70	16954.65
24	Market Rate	Supply and fixing of indemnification boar size 18 gauge sheet 18"x18" painted writing of tube well no etc i/c fixing at site. (Market Rate).	1.00	P.Job	3000.00	3000.00
						4125876

BILL OF QUANTITIES FOR SOLAR ENERGY BASED SCHEMES / PROJECTS/WORKS ETC				
NAME OF WORK:				
S.No	Description	Unit Rate (Rs) including installation Price (A)	Quantity (B)	Total Amount (Rs) (A x B)
1				
2				
3				
4				
5 & so on				
Total amount (Rs)				
Note: following information is to be provided by the bidder, otherwise bid shall be declared as non responsive. (Must be duly supported by evidence of exemption)				
Amount exempted from Federal GST (PKR)				
Amount Chargeable to % federal (FBR) sales Tax on goods (PKR)				
Federal (FBR) sales Tax on goods @ %(PKR)				
Amount chargeable to % provincial (KPRA) sales Tax on Services (PKR)				
Provincial KPRA Tax on services @ % (PKR)				
Any other applicable Tax.				
Total				

# **INSTRUCTIONS TO BIDDERS**

## INSTRUCTIONS TO BIDDERS

# Table of Contents

<b>A. General .....</b>	<b>5</b>
IB 1. Scope of Bid	5
IB 2. Source of Funds .....	5
IB 3. Eligible Bidders .....	5
IB 4. One Bid per Bidder .....	5
IB 5. Eligible Goods and Services .....	5
IB 6. Cost of Bidding.....	5
<b>B. Bidding Documents.....</b>	<b>6</b>
IB 7. Contents of Bidding Documents.....	6
IB 8. Clarification of Bidding Documents .....	6
IB 9. Amendment of Bidding Documents .....	7
<b>C. Preparation of Bids.....</b>	<b>7</b>
IB 10. Language of Bid.....	7
IB 11. Documents Accompanying the Bid .....	9
IB 12. Letter of Bid and Schedules .....	8
IB 13. Bid Prices	9
IB 14. Currencies of Bid and Payment.....	10
IB 15. Documents Establishing Bidder's Eligibility and Qualification .....	10
IB 16. Documents Establishing Good's Eligibility .....	12
IB 17. Bid Security	13
IB 18. Bid Validity	14
IB 19. Format and Signing of Bid .....	14
<b>D. Submission of Bids.....</b>	<b>15</b>
IB 20. Sealing and Marking of Bids .....	15
IB 21. Deadline for Submission of Bids .....	15
IB 22. Late Bids	16
IB 23. Modification, Substitution and Withdrawal of Bids .....	16
<b>E. Bid Opening and Evaluation.....</b>	<b>17</b>
IB 24. Bid Opening	17
IB 25. Clarification of Bids.....	17
IB 26. Preliminary Examination & Determination of Responsiveness.....	19
IB 27. Conversion to Single Currency.....	19
IB 28. Detailed Evaluation of Bids .....	19
IB 29. Domestic Preference .....	21
IB 30. Process to be Confidential .....	22

<b>F. Award of Contract .....</b>	<b>23</b>
IB 31. Post-Qualification .....	23
IB 32 Award Criteria .....	23
IB 33. Employer’s Right to Vary Quantities.....	23
IB 34 Employer’s Right to Accept any Bid and to Reject any or all Bids .....	23
IB 35. Notification of Award .....	24
IB 36. Performance Security .....	24
IB 37 Signing of Contract Agreement .....	24
<b>G. Additional Instructions .....</b>	<b>24</b>
IB 38. Instructions not Part of Contract .....	24
IB 39. Contract Documents .....	24
IB 40. Sufficiency of Bid .....	25
IB 41. Bidder to Inform Himself.....	25
IB 42. Alternate Proposals by Bidder .....	25
IB 43. Local Conditions .....	25
IB 44. Integrity Pact .....	25



<b>H. BIDDING DATA.....</b>	<b>27</b>
<b>I. ANNEXURE</b>	
<b>Annexure-A TO Bidding Data, Name of eligible countries</b>	<b>28</b>
<b>Annexure-B TO Bidding Data, Evidence of Bidder’s Eligibility and Qualification</b>	<b>29</b>
<b>Annexure-C TO Bidding Data, Domestic Goods (value added in Pakistan)</b>	<b>33</b>
<b>LETTER OF BID AND APPENDICES TO BID .....</b>	<b>49</b>
<b>STANDARD FORMS .....</b>	<b>79</b>

## INSTRUCTIONS TO BIDDERS

*[Note: These Instructions to Bidders along with Bidding Data not be the part of Contract and will cease to have effect once the contract is signed.]*

### A. GENERAL

- |      |                                     |     |   |
|------|-------------------------------------|-----|---|
| IB.1 | Scope of Bid                        | 1.1 | <p>The Employer as defined in the Bidding Data hereinafter called “the Employer” wishes to receive bids for the construction and completion of works as described in these Bidding Documents, and summarised in the Bidding Data hereinafter referred to as the “Works”.</p> <p>Bidders must quote for the complete scope of work. Any bid covering partial scope of work will be rejected as non-responsive, pursuant to Clause IB.24.</p> |
|      | Source of Funds                     | 2.1 | <p>The Employer has applied for/received a Fund from the source(s) in various currencies towards the cost of the project specified in the Bidding Data and it is intended that part of the proceeds of this fund will be applied to eligible payments under the Contract for which these Bidding Documents are issued.</p>  |
|      | Eligible Bidders                    | 3.1 | <p>Bidding is open to all all firms and Joint Ventures of firms meeting the requirements Specified in Bidding Data.</p>   |
|      | One Bid per Bidder                  | 4.1 | <p>Each bidder shall electronically submit only one bid either by himself, or as a partner in a joint venture. A bidder who submits or participates in more than one bid (other than alternatives if provision exists, pursuant to Clause IB.42) will be disqualified.</p>  |
|      | Eligible Goods and related Services | 1.1 | <p>All Goods and ancillary Services to be supplied under this Contract shall have their origin in eligible countries listed in Annexure-A stated in Bidding Data and all expenditures made under the Contract will be limited to such Goods and Services.</p>   |
|      |                                     | 1.2 | <p>For purpose of this Clause, the term “goods” includes commodities, raw material, machinery, equipment, and industrial plants; and “related services” includes services such as insurance, installation, training, and initial maintenance.</p>   |
|      |                                     | 1.3 | <p>The term “origin” means the place where the Goods are mined, grown or produced or from where the ancillary services are supplied. Goods are produced when, through manufacturing, processing or substantial and major assembling of components, a commercially recognized product results that is substantially different in basic characteristics or in purpose or utility from its components.</p>                                     |
|      |                                     | 1.4 | <p>The origin of Goods and Services is distinct from the nationality of the Bidder.</p>   |
|      | Cost of Bidding                     | 6.1 | <p>The bidders shall bear all costs associated with the preparation and submission of their respective bids and the Employer will in no case be responsible or liable for those costs, regardless of the conduct or outcome of the bidding process.</p>   |
|      |                                     | 6.2 | <p>The bidders are advised to visit and examine the Site of Works and its surroundings and obtain for themselves on their own responsibility all information that may be necessary for preparing the bid and entering into a contract for execution of the Works. All cost in this respect shall be at the bidder’s own expense.</p>  |
|      |                                     | 6.3 | <p>The bidders and any of their personnel or agents will be</p>   |

granted permission by the Employer to enter upon his premises and lands for the purpose of such inspection, but only upon the express condition that the bidders, their personnel and agents, will release and indemnify the Employer, his personnel and agents from and against all liability in respect thereof and will be responsible for death or personal injury, loss of or damage to property and any other loss, damage, costs and expenses incurred as a result of such inspection.

**B. BIDDING DOCUMENTS**

Contents of Bidding Documents

7.1 The Bidding Documents, in addition to invitation for bids, are those stated below and should be read in conjunction with any Addenda issued in accordance with Clause IB.8 & 9:

1. Instructions to Bidders
2. Bidding Data
3. General Conditions (GC)
4. Particular Conditions (PC)
  - Part-A: Contract Data
  - Part-B: Specific Provisions
5. Specification - Special Provisions
6. Specification - Technical Specifications
7. Letter of Bid
8. Appendices to Bid
9. Standard Form
  - i) Form of Bid Security
  - ii) Form of Contract Agreement
  - iii) Form of Performance Security
  - iv) Form of Mobilization Advance Guarantee
10. Drawings

7.2 The bidders are expected to examine carefully the contents of all the above documents. Failure to comply with the requirements of bid submission will be at the Bidder's own risk. Pursuant to Clause IB 28, bids which are not substantially responsive to the requirements of the Bidding Documents will be rejected.

Clarification of Bidding Documents

8.1 Any prospective bidder requiring any clarification (s) in respect of the Bidding Documents may notify the Employer in writing at the Employer's address indicated in the Bidding Data.

The Employer will respond to any request for clarification which he receives earlier than the period specified in the Bidding Data, prior to the deadline for submission of bids.

Copies of the Employer's response will be forwarded to all purchasers of the Bidding Documents, including a description of the enquiry but without identifying its source.

8.2 The Employer may, on his own or at the request of any prospective bidder(s), hold a pre-bid meeting to clarify issues and to answer any questions on matters related to the Bidding Documents. The date, time and venue of pre-bid meeting, if convened, are as stipulated in the Bidding Data. All prospective bidders or their authorized representatives shall be invited to attend such a pre-bid meeting.

8.3 Absence at the pre-bid meeting will not be a cause for disqualification of a bidder.

- Amendment of Bidding Documents
- 9.1 At any time prior to the deadline for submission of bids, the Employer may, for any reason, whether at his own initiative or in response to a clarification requested by a prospective bidder, modify the Bidding Documents by issuing addendum.
- 9.2 Any addendum thus issued shall be part of the Bidding Documents pursuant to Sub Clause IB 9.1 hereof and shall be communicated in writing to all purchasers of the Bidding Documents. Prospective bidders shall acknowledge receipt of each addendum in writing to the Employer.
- 9.3 To afford prospective bidders reasonable time in which to take an addendum into account in preparing their bids, the Employer may extend the deadline for submission of bids in accordance with Clause IB.22.
- C. PREPARATION OF BIDS**
- Language of Bid
- 10.1 The Bid prepared by the Bidder and all correspondence and documents relating to the Bid, exchanged by the Bidder and the Engineer shall be written in the English language, provided that any printed literature furnished by the Bidder may be written in another language so long as accompanied by an English translation of its pertinent passages in which case, for purposes of interpretation of the Bid, the English translation shall govern as specified in Bidding Data.
- Documents Comprising the Bid
- 11.1 The bid prepared by the bidder shall comprise the following components:
- (a) Electronically Bid Submission Letter;
  - b) Letter of Bid duly filled, signed and sealed, in accordance with Clause IB.19;
  - c) Appendices (A to K) to Bid duly filled and signed, in accordance with the instructions contained therein.
  - d) Bill of Prices completed in accordance with Clauses IB.13 and 14;
  - e) Bid Security furnished in accordance with Clause IB.17;
  - f) Power of Attorney in accordance with Clause IB 19.5.
  - g) Joint Venture Agreement (if applicable). One of the joint venture partners shall be nominated as being in charge; and this authorization shall be evidenced by submitting a power of attorney signed by legally authorized signatories of all the joint venture partners;
  - h) Documentary evidence established in accordance with Clause IB.15 that the bidder is eligible to bid and is qualified to perform the contract if its bid is accepted;
  - i) Documentary evidence established in accordance with Clause IB.16 that the Goods and ancillary Services to be supplied by the bidder are eligible Goods and Services and conform to the Bidding Documents;
  - j) Bidders applying for eligibility for domestic preference in bid evaluation shall supply all information & evidence to establish the claim for domestic preference required to satisfy the criteria for eligibility as described in Clause IB.29. The particulars for domestic Goods prescribed in Annexure-c mentioned in Bidding Data shall also be filled in to substantiate claim for domestic preference;
  - k) Any other documents prescribed in Contract Data, Contract Data, PC of Contract or Technical Provisions to be submitted with the bid.

Letter of Bid and  
Appendices

12.1 The bidder shall complete, sign and seal the Letter of Bid and Appendices (A to K, or as modified) to Bid furnished in the Bidding Documents and shall also enclose other information as detailed in Clause IB.11.

12.2 For the purpose of granting a margin of domestic preference pursuant to Clause IB.29, the Employer/Engineer will classify the bids, when submitted in one of three groups as follows:

(a) Group 'A' Bid.

(i) For Goods for which labour, raw materials and components from within Pakistan account for at least 20% of the ex-factory bid price of the products offered.

(ii) For Goods for which labour, raw materials and components from within Pakistan account for over 20% and up to 30% of the ex-factory bid price of the products offered.

(iii) For Goods for which labour, raw materials and components from within Pakistan account for over 30% of the ex-factory bid price of the products offered.

(b) Group 'B' Bid.

For Goods manufactured in Pakistan for which the domestic value added in the manufacturing cost is less than 20% of the ex-factory bid price; and

(c) Group 'C' Bid.

For Goods of foreign origin. In preparing their bids, the bidders, whether local or foreign, shall enter in the Bill of Quantities ex-factory price for indigenously manufactured products and CIF price as well as customs duty and sales tax and other import charges for products to be imported from outside Pakistan.

Bid Prices

13.1 The price and discount if any quoted by the Bidders in the Letter of Bid and in the Bill of Quantity shall conform to the requirement specified below:

13.2 The bids are to be electronically submitted set of the BOQ with prices entered by the bidder in accordance with the instructions issued herein in case of any difference, the electronic bid will provided.

13.3 The bidder shall fill in rates and prices for all items of the Works described in the Bill of Quantities. Items against which no rate or price is entered by a bidder will not be paid for by the Employer when executed and shall be deemed covered by rates and prices for other items in the Bill of Quantities.

13.4 The bidder's separation of price components in accordance with Sub-Clause 13.2 above, will be solely for the purpose of facilitating the comparison of bids by the Employer/Engineer and will not in any way limit its right to contract on any of the terms offered.

13.5 Unless otherwise stipulated in the Conditions of Contract, prices quoted by the bidder shall remain fixed during the bidder's performance of the Contract and not subject to variation on any account. When the bidders are required to quote only fixed price(s) a bid submitted with an adjustable price quotation will be treated as non-responsive and rejected, pursuant to Clause IB.26.

13.6 Additional / reduced levies due to subsequent changes in legislation shall be reimbursed / deducted as per Sub-Clause 13.7 of the General Conditions (GC).

- 13.7 If the rates and prices quoted by the bidders are subject to adjustment during the performance of the Contract in accordance with the provisions of Sub Clause 13.8 of the General Conditions (GC). The bidders shall furnish the prescribed information for the price adjustment formulae in Appendix-A to Bid, and shall submit with their bids such other supporting information as required under the said Sub Clause.
- 13.8 Any discount offered shall be valid for at least the period of validity of the bid. A discount valid for lesser period shall be considered null and void.
- Currencies of Bid
- 14.1 Prices shall be quoted in the following currencies: (Pak Rs)
- (a) For Goods and Services which the bidder will supply from within Pakistan, the prices shall be quoted in the Pak. Rupees.
- (b) For Goods and Services which the bidder will supply from outside Pakistan, the prices shall be quoted either in U.S. Dollars or in any other freely convertible currency.
- 14.2 Further, a bidder expecting to incur a portion of its expenditure in the performance of the Contract in more than one currency (but use no more than 3 foreign currencies), and wishing to be paid accordingly, shall so indicate in its bid under Appendix-A to Bid.
- 14.3 The currencies of payment shall be as stated in Particular Conditions under appendix-A to bid. However, provisions in Sub-Clauses 14.1 & 14.2 above, shall not in any way constitute a contractual or legal binding on the Employer for the payment in the currencies required by the Contractor.
- Documents Establishing Bidder's Eligibility and Qualifications
- 15.1 Pursuant to Clause IB.9, the bidder shall furnish, as part of its bid, documents establishing the bidder's eligibility to bid and its qualifications to perform the Contract if its bid is accepted.
- 15.2 The documentary evidence of the bidder's eligibility to bid shall establish to the Employer's satisfaction that the bidder, at the time of submission of its bid is from an eligible source country as defined under Clause IB.3.
- 15.3 The documentary evidence of the bidder's qualification to perform the Contract if its bid is accepted, shall establish to the Employer's/Engineer's satisfaction:
- (a) that, in the case of a bidder offering to supply Goods under the Contract which the bidder did not manufacture or otherwise produce, the bidder has been duly authorized by the Goods manufacturer or producer to supply the Goods to Pakistan. In this regard The bidder shall submit Manufacturers Authorization letter
- (b) that the Bidder/Manufacturer has the financial, technical and production capability necessary to perform the Contract; and
- (c) that, in the case of a bidder not doing business within Pakistan the bidder is or will be (if successful) represented by an agent in Pakistan equipped and able to carry out the Supplier's maintenance, repair and spare parts stocking obligations prescribed by the Conditions of Contract and/or Technical Provisions. In such case Bidder's certification is necessary.
- (d) The bidder (including all partners of joint venture and subcontractors of a bidder) shall not be under liquidation/blacklisted by the Employer or any other agency.
- 15.4 (a) Bidder/Manufacturer must possess and provide evidence of experience as mentioned in the Bidding Data;  
The Bidder shall certify the capacity and capability of the plant (from

which Goods are now offered) for manufacturing, quality assurance and testing facilities, qualified man-power and production/delivery of quality materials according to bid specifications and delivery requirements. The numbers of years of working of such plant having production of same required items and numbers years and such Goods shall have proven successful in the field are mentioned in the Bidding Data.

The bidder shall submit with the bid all necessary documentation in this regard. The Employer/Engineer will have the right to verify the particulars regarding the plant and other related information furnished with the bid and the joint venture as well as the partners thereof shall be liable for disqualification in the event of any mis-statement/mis-representation on their part.

The bidder shall furnish documentary evidence of qualification on the Form "Evidence of Bidder's Eligibility and Qualifications" specified in Bidding Data.

- (b) The bidder should have an average annual turnover in the last five years equal to or more than the Total Bid Price. Alternately, the bidder should have successfully completed in the last five years any specific project having value equal to or higher than the total Bid Price. In this regard the bidder has to submit with his bid valid PC.

15.5 Joint Venture: In order for a Joint Venture to qualify;

- (a) At least one of the partners of joint venture shall satisfy the relevant experience criteria specified in Sub-Clause 15.4(a) hereinabove.
- (b) All firms comprising the joint venture shall be legally constituted and shall meet the eligibility requirement of Sub-Clause 3.1 hereof.
- (c) All partners of the joint venture shall at all times and under all circumstances be liable jointly and severally to Employer for the execution of the entire Contract in accordance with the Contract terms and conditions and a statement to this effect shall be included in the authorization mentioned under para (f) below as well as in the Letter of Bid and Form of Contract Agreement (in case of a successful bidder).
- (d) The Letter of Bid, and in the case of successful bidder, the Form of Contract Agreement, shall be signed so as to be legally binding on all partners.
- (e) One of the joint venture partners shall be nominated as being in-charge and this authorisation shall be evidenced by submitting a power of attorney signed by legally authorized signatories of all the joint venture partners.
- (f) The partner-in-charge shall be authorized to incur liabilities, receive payments and receive instructions for and on behalf of any or all partners of the joint venture.
- (g) A copy of the agreement entered into by the joint venture partners shall be submitted with the bid stating the conditions under which it will function, its period of duration, the persons authorized to represent and obligate it and which persons will be directly responsible for due performance of the Contract and can give valid receipts on behalf of the joint venture, the proportionate participation of the several firms forming the joint venture, and any other information necessary to permit a full appraisal of its functioning. No amendments / modifications whatsoever in the joint venture agreement shall be agreed to between the joint

venture partners without prior written consent of the Employer.

Documents  
Establishing Goods'  
Eligibility

15.6 The Bidder shall propose, in order of his priority; plant, equipment or goods of not more than three Manufacturers. Employer at his own jurisdiction will evaluate the plant, equipment or goods of only one of such Manufacturers.

16.1 Pursuant to Clause IB.9, the bidder shall furnish, as part of its bid, documents establishing the eligibility and conformity to the Bidding Documents of all Goods and Services which the bidder proposes to perform under the Contract.

16.2 The documentary evidence of the Goods and Services eligibility shall establish to the Employer's satisfaction that they will have their origin in an eligible source country as defined under Clause IB.5. A certificate of origin issued at the time of shipment will satisfy the requirements of the said Clause.

16.3 The documentary evidence of the Goods and Services' conformity to the Bidding Documents may be in the form of literature, drawings and data and shall furnish:

(a) A detailed description of the Goods, essential technical and performance characteristics.

(b) Complete set of technical information, description data, literature and drawings as required in accordance with Appendix-C to Bid, Specific Works Data. This will include but not be limited to the following;

(i) A sufficient number of drawings, photographs, catalogues, illustrations and such other information as is necessary to illustrate clearly the significant characteristics such as general construction dimensions and other relevant information about the Goods to be furnished.

(ii) Details of equipment and machinery with capacity.

(iii) Any other information which is required for evaluation purposes.

(c) A clause-by-clause commentary on Technical Provisions, provided with the Bidding Documents, demonstrating the Goods' and Services' substantial responsiveness to those Specifications or a statement of deviations and exceptions to the provisions of the Technical Provisions as required in Appendix-F to Bid.

16.4 For purpose of the commentary to be furnished pursuant to Sub-Clause 16.3(c) above, the Bidder shall note that standards for workmanship, material and equipment, and references to brand names or catalogue numbers, designated by the Engineer in the Technical Provisions are intended to be descriptive only and not restrictive. The bidder may substitute alternative standards, brand names and/or catalogue numbers in its bid, provided that it demonstrates to the Engineer's satisfaction that the substitutions are substantially equivalent or superior to those designated in the Technical Provisions. Copies of the standards proposed by the bidder other than those specified in the Bidding Documents shall be furnished.

Bid Security

17.1 Each bidder shall furnish, as part of his bid, a Bid Security in original form in the amount stipulated in the Bidding Data in Pak Rupees or an equivalent amount in a freely convertible currency.

The Bid Security of Joint Venture must be in the name of Joint Venture submitting the bid.



- 17.2 The contractor quoting their bid more than 15% below on Engineer's estimate shall submit an additional bid security to the extent of bid/rate more than 15% below on Engineer estimate along with the 2% bid security at the time of bid submission. "KPPRA Notification No.SRO(13)/Vol:2021-22, dated 15.9.2021 as well as other notifications from time to time will be applicable"
- 17.3 The Bid Security is required to protect the Employer against the risk of bidder's conduct which would warrant the security's forfeiture, pursuant to Sub-Clause 17.7 hereof.
- 17.4 Any bid not accompanied by an acceptable Bid Security additional bid security as the case may be rejected by the Employer as non-responsive, pursuant to Clause IB.26.
- 17.5 The bid securities of unsuccessful bidders will be returned upon award and signing of contract to with the successful bidder or on the expiry of validity of Bid Security whichever is earlier.
- 17.7 The Bid additional Security may be forfeited:
- (a) if a bidder withdraws his bid during the period of bid validity; or
  - (b) if a bidder does not accept the correction of his Bid Price, pursuant to Sub-Clause 26.2 hereof; or
  - (c) in the case of a successful bidder, if he fails to:
    - (i) sign the Contract Agreement, in accordance with Clause IB.37.
- 17.8 In case of annulment, all bids submitted and specially, bid securities, shall be returned to the Bidders within 14 days of annulment.

#### Bid Validity

- 18.1 Bids shall remain valid for the period stipulated in the Bidding Data after the Date of Bid Opening as prescribed in Clause IB.21.
- 18.2 In exceptional circumstances prior to expiry of original bid validity period, the Employer may request the bidders to extend the period of validity for a specified additional period which shall in no case be more than the original bid validity period. The request and the responses thereto shall be made in writing. A bidder may refuse the request without forfeiture of his Bid Security. A bidder agreeing to the request will be required to extend the validity of his Bid Security for the period of the extension, and in compliance with Clause IB.17 in all respects in which case, the Employer will be obligated to compensate the bidders, upon substantiation for their increase in costs.

#### Format and Signing of Bid

- 19.1 Bidders are particularly directed that the amount entered on the Letter of Bid shall be for performing the Contract strictly in accordance with the Bidding Documents.
- 19.2 All appendices to Bid are to be properly completed and signed.
- 19.3 No alteration is to be made in the Letter of Bid nor in the Appendices thereto except in filling up the blanks as directed. If any such alterations be made or if these instructions be not fully complied with, the bid may be rejected.
- 19.4 Each bidder shall prepare by filling out the forms completely and without alterations one (1) original and number of copies, specified in the Bidding Data, of the documents comprising the bid as described in Clause IB.11 and clearly mark them "ORIGINAL" and "COPY" as appropriate. In the event of discrepancy between them, the original shall prevail.
- 19.5 The original and all copies of the bid shall be typed or written in indelible ink and shall be signed by a person or persons duly authorized to sign (in the case of copies, Photostats are also

acceptable). This shall be indicated by submitting a written Power of Attorney authorising the signatory of the bidder to act for and on behalf of the bidder. All pages of the bid shall be initialed and stamped by the person or persons signing the bid.

19.6 The bid shall contain no alterations, omissions or additions, except to comply with instructions issued by the Employer, or as are necessary to correct errors made by the bidder, in which case such corrections shall be initialed by the person or persons signing the bid.

19.7 Bidders shall indicate in the space provided in the Letter of Bid their full and proper addresses at which notices may be legally served on them and to which all correspondence in connection with their bids and the Contract is to be sent.

19.8 Bidders should retain a copy of the Bidding Documents as their file copy.

#### **D. SUBMISSION OF BIDS**

Sealing and  
Marking of Bids

20.1 Each bidder shall submit his bid as under:

(a) ORIGINAL and each copy of the Bid shall be separately sealed and put in separate envelopes and marked as such.

(b) The envelopes containing the ORIGINAL and copies will be put in one sealed envelope and addressed / identified as given in Sub Clause IB 19.2 hereof.

20.2 The inner and outer envelopes shall:

(a) be addressed to the Employer at the address provided in the Bidding Data.

(b) bear the name and identification number of the contract as defined in the Bidding Data; and

(c) provide a warning not to open before the time and date for bid opening, as specified in the Bidding Data.

20.3 The Bid shall be submitted electronically while the call deposit and other required documents should be submitted in person or sent by registered mail at the address to Employer as given in Sub-Clause 8.1 heretofore.

20.4 In addition to the identification required in Sub-Clause 20.2 hereof, the inner envelope shall indicate the name and address of the bidder to enable the bid to be returned unopened in case it is declared "late" pursuant to Clause IB.22.

20.5 If the outer envelope is not sealed and marked as above, the Employer will assume no responsibility for the misplacement or premature opening of the bid.

Deadline for  
Submission of Bids

21.1 (a) Bids must be received by the Employer at the address specified in Sub-Clause 8.1 hereof not later than the time and date stipulated in Bidding Data and should match the information given in the Invitation for Bids.

(b) Bids with charges payable will not be accepted, nor will arrangements be undertaken to collect the bids from any delivery point other than that specified above. Bidders shall bear all expenses incurred in the preparation and delivery of bids.

(c) The Bid shall be submitted electronically while the call deposit and other required documents should be submitted in person or sent by registered mail at the address to Employer as given in Sub-Clause 8.1 heretofore.

(d) Upon request, acknowledgment of receipt of bids will be provided to those making delivery in person or by

messenger.

21.2 Bids submitted through telegraph, telex, fax or e-mail shall not be considered.

21.3 The Employer may, at his discretion, extend the deadline for submission of bids by issuing an addendum in accordance with Clause IB.9, in which case all rights and obligations of the Employer and the bidders previously subject to the original deadline will thereafter be subject to the deadline as extended

Late Bids

22.1 (a) Any bid received by the Employer after the deadline for submission of bids prescribed in Clause IB.20 will be returned unopened to such bidder.

(b) Delays in the mail, delays of person in transit, or delivery of a bid to the wrong office shall not be accepted as an excuse for failure to deliver a bid at the proper place and time. It shall be the bidder's responsibility to determine the manner in which timely delivery of his bid will be accomplished either in person, by messenger or by mail.

Modification,  
Substitution and  
Withdrawal of Bids

23.1 Any bidder may modify, substitute or withdraw his bid after bid submission provided that the modification, substitution or written notice of withdrawal is received by the Employer prior to the deadline for submission of bids.

23.2 The modification, substitution, or notice for withdrawal of any bid shall be prepared, sealed, marked and delivered in accordance with the provisions of Clause IB.20 with the outer and inner envelopes additionally marked "MODIFICATION", "SUBSTITUTION" or "WITHDRAWAL" as appropriate.

23.3 Withdrawal of a bid during the interval between the deadline for submission of bids and the expiration of the period of bid validity specified in the Letter of Bid may result in forfeiture of the Bid Security pursuant to Clause IB.17.

#### **E. BID OPENING AND EVALUATION**

Bid Opening

24.1 A committee consisting of nominated members by the Employer and by the Engineer will open the bids, including withdrawals, substitution and modifications made pursuant to Clause IB.23, in the presence of bidders' representatives who choose to attend, at the time, date and location stipulated in Bidding Data and should match the information given in the Invitation for Bids.

The bidders' representatives who are present shall sign in a register evidencing their attendance.

24.2 Envelopes marked "MODIFICATION", "SUBSTITUTION" or "WITHDRAWAL" shall be opened and read out first. Bids for which an acceptable notice of withdrawal has been submitted pursuant to Clause IB.23 shall not be opened.

24.3 The bidder's name, total Bid Price and price of any Alternate Proposal(s), any discounts, bid modifications, substitution and withdrawals, the presence or absence of Bid Security, and such other details as the Employer may consider appropriate, will be announced by the Employer at the opening of bids. The Employer will record minutes of bid opening.

Any Bid Price or discount which is not read out and recorded at bid opening will not be taken into account in the evaluation of bid.

24.4 Discounts offered for lesser period than the bid validity shall

- not be considered in evaluation.
- Clarification of Bids 25.1 To assist in the examination, evaluation and comparison of Bids the Engineer may, at its discretion, ask the Bidder for a clarification of its Bid. The request for clarification and the response shall be in writing and no change in the price or substance of the Bid shall be sought, offered or permitted.
- Examination of Bids and Determination of Responsiveness 26.1 Prior to the detailed evaluation of bids, pursuant to Clause IB.28.
- (a) the Engineer will examine the Bids to determine whether;
    - (i) the Bid is complete and does not deviate from the scope,
    - (ii) any computational errors have been made,
    - (iii) required sureties mandatory requirements have been furnished,
    - (iv) the documents have been properly signed,
    - (v) the Bid is valid till required period,
    - (vi) the Bid prices are firm during currency of contract if it is a fixed price bid,
    - (vii) completion period offered is within specified limits,
    - (viii) the Bidder/Manufacturer is eligible to Bid and possesses the requisite experience,
    - (ix) the Bid does not deviate from basic technical requirements and
    - x) the Bids are generally in order.
  - (b) A bid is likely not to be considered, if;
    - (i) it is unsigned,
    - (ii) its validity is less than specified,
    - (iii) it is submitted for incomplete scope of work,
    - (iv) it indicates completion period later than specified, and
    - v) it indicates that Works including plant and materials to be supplied do not meet eligibility requirements,
  - (c) A bid will not be considered, if;
    - (i) it is not accompanied with bid security/additional security as the case may be
    - (ii) it is submitted by a bidder who has participated in more than one bid,
    - (iii) it is received after the deadline for submission of bids,
    - (iv) it is submitted through fax, telex, telegram or email,
    - (v) it indicates that prices quoted are not firm during currency of the contract whereas the bidders are required to quote fixed price(s),
    - (vi) the bidder refuses to accept arithmetic correction,
    - (vii) the bidder and its manufacturer of major Plant do not meet the requisite qualification criteria, and
    - (viii) it is materially and substantially different from the Conditions/Specifications of the Bidding Documents.
    - (ix) The bid not supported by the mandatory required documents.
- 26.2 Arithmetical errors will be rectified on the following basis; If there is a discrepancy between the unit price and total price that is obtained by multiplying the unit price and quantity, the unit price shall prevail and the total price shall be corrected. If there is a discrepancy between the words and figures the amount in words shall prevail. If there is a discrepancy between the total Bid price entered in Letter of Bid and the total shown in Bill of Quantities Summary, the amount stated in the Letter of Bid will be corrected by the Employer/Engineer in accordance with the Corrected Bill of Quantities.
- If the Bidder does not accept the corrected amount of Bid, his Bid will be rejected and his Bid Security forfeited.

26.3 Prior to the detailed evaluation, pursuant to Clause IB.26 the Employer/Engineer will determine the substantial responsiveness of each Bid to the Bidding Documents. For purpose of these Clauses, a substantially responsive Bid is one which conforms to all the terms and conditions and reflected in NIT the Bidding Documents without material deviations.

A material deviation or reservation is one:

- (i) which affects in any substantial way the scope, quality or performance of the Works,
- (ii) which limits in any substantial way, inconsistent with the Bidding Documents, the Employer's rights or the bidder's obligations under the Contract; or
- (iii) whose rectification/adoption would affect unfairly the competitive position of other bidders presenting substantially responsive bids.
- (iv) Non availability of mandatory requirements/documents

The Employer's/Engineer's determination of a Bid's responsiveness will be based on the contents of the Bid itself without recourse to extrinsic evidence.

26.4 A Bid determined as substantially non-responsive will be rejected and will not subsequently be made responsive by the Bidder by correction of the non-conformity.

26.5 Any minor informality or non-conformity or irregularity in a Bid which does not constitute a material deviation may be waived by Employer, provided such waiver does not prejudice or affect the relative ranking of any Bidder.

Conversion to Single  
Currency

27.1 To facilitate evaluation and comparison, the Employer/Engineer will convert, all Bid Prices expressed in the amount in various currencies in which Bid Price is payable, to Pak. Rupees at the Telegraphic Transfer and Over Draft (TT&OD) composite (selling) exchange rates published/authorised by State Bank of Pakistan and applicable to similar transactions, on the date of the opening of Bids.

Detailed Evaluation of  
Bids

28.1 The Employer/Engineer will evaluate and compare only the bids previously determined to be substantially responsive pursuant to Clause IB.26 as per requirements given hereunder.

28.2 Evaluation and Comparison of Bids:

- (a) Bids will be evaluated for complete scope of work,
- (b) Basis of Price Comparison;

The prices will be compared on the basis of the Evaluated Bid Price pursuant to Para (e) herein below.

(c) Technical Evaluation;

It will be examined in detail whether the Goods offered by the bidder comply with the Technical Provisions of the Bidding Documents. For this purpose, the bidder's data submitted with the bid will be compared with the specific work data prescribed by the Employer and technical features/criteria of the Goods detailed in the Technical Provisions. Other technical information submitted with the bid regarding the Scope of Work will also be reviewed.

(d) Commercial Evaluation;

It will be examined in detail whether the bids comply with the commercial/contractual conditions of the Bidding Documents. It is

expected that no major deviation/stipulation shall be taken by the bidders.

**Evaluated Bid Price;**

In evaluating the bids, the Employer will determine for each bid in addition to the Bid Price, the following factors (adjustments) in the manner and to the extent indicated below to determine the Evaluated Bid Price:

- (i) making any correction for errors pursuant to Sub-Clause 26.2 hereof,
- (ii) excluding Provisional Sums, if any, but including priced Daywork,
- (iii) making an appropriate adjustment for any other acceptable variation or deviation.
- (iv) The bids offered electronically will prevail provided the mandatory requirements are met as specified.

**28.3 Evaluation Methods:**

Pursuant to Sub-Clause 28.2, Para (e) (iii) following evaluation methods for price adjustments will be followed;

- (a) Price Adjustment for Completeness in Scope of Work,
- (b) Price Adjustment for Technical Compliance,
- (c) Price Adjustment for Commercial Compliance,
- (d) Price Adjustment for Deviations in Terms of Payment,
- (e) Price Adjustment for completion Schedule,

**(i) Price Adjustment for Completeness in Scope of Work:**

In case of omission in the scope of work of a quoted item, no price adjustment for the omitted item(s) shall be applied provided that the Bidder has mentioned in his bid that the same is covered in any other item, otherwise price adjustment will be applied for evaluation purposes only, taking the highest price(s) of omitted item (s) quoted by other bidders.

The price adjustment shall not justify any additional payment by the Employer. The price(s) of omitted item(s) shall be deemed covered by other prices of the Bill of Quantities.

**(ii) Price Adjustment for Technical Compliance:**

The cost of making good any deficiency resulting from technical non compliance will be added to the Corrected Total Bid Price for comparison purposes only. The adjustments will be applied taking the highest price quoted by other Bidders being evaluated in detail in their original Bids for corresponding item. In case of non availability of price from other Bidders, the price will be estimated by the Engineer.

**(iii) Price Adjustment for Commercial Compliance:**

The cost of making good any deficiency resulting from any quantifiable variations and deviations from the Bid Schedules and Conditions of Contract, as determined by the Engineer will be added to the Corrected Total Bid Price for comparison purpose only. Adjustment for commercial compliance will be based on Corrected Total Bid Prices.

**(iv) Price Adjustment for Deviation in Terms of Payment:**

If a bid deviates from the terms of payment/payment conditions as specified in the Conditions of Contract and if such deviation is considered acceptable to the Employer, mark-up earned for any earlier payments involved in the terms outlined in the Bid as compared to those stipulated in the Conditions of Contract shall be calculated at the following mark-up rates:

- for foreign currency component: LIBOR+1%

- for local currency component: KIBOR+2% and shall be added to the Corrected Total Bid Price for comparison purposes only.

(v) Price Adjustment for Completion Schedule:

Bids indicating completion in advance of the dates stated in the Contract Data, no credit will be given in this evaluation.

Bids indicating completion period later than the period set out in the Contract Data shall be adjusted in the evaluation by adding a factor of 0.05% of the Corrected Total Bid Price for each calendar day of completion later than specified period of the completion.

Bids indicating completion beyond 180 days later than the dates set out in the Contract Data, shall not be considered and rejected as non responsive.

28.4 If the bid of the successful bidder is seriously unbalanced in relation to the Employer's estimate of the cost of work to be performed under the Contract, the Employer may require the bidder to produce detailed price analyses for any or all items of the Bill of Quantities to demonstrate the internal consistency of those prices with the construction methods and schedule proposed. If the bid offered is more than 10% below, the bidder has to furnish call deposit @ 8% of estimated cost as additional security and will be released of successful complete and expiry of D.L.C.

Domestic Preference

29.1 In the comparison of evaluated Bids, the Goods manufactured in Pakistan, will be granted a margin of preference in accordance with the following procedures, provided the bidder shall have established to the satisfaction of Employer that the manufacturing cost of such Goods includes a domestic value addition equal to at least 20% of the ex-factory Bid price of such Goods. Bidders applying for domestic preference shall fill in Annexure-C to Bidding Data to substantiate their claim, failing which the bidder shall not be eligible to claim domestic preference.

29.2 The Employer/Engineer will first review the Bids to determine, the Bid group classification in accordance with Sub-Clause 12.2 hereof.

29.3 The comparison shall be Ex-factory price of the Goods to be offered from within Pakistan (such prices to include all costs as well as custom duties and taxes paid or payable on raw materials and components incorporated or to be incorporated in the Goods) and the DDP (CIF + Customs duty, sales tax and other import charges) Pakistan seaport price of the Goods to be offered from outside Pakistan.

29.4 The lowest evaluated bid of each Group shall first be determined by comparing all evaluated bids in each Group among themselves taking into account:

(a) In the case of Goods manufactured in Pakistan, sales tax, local body charges and other similar taxes which will be payable on the furnished Goods in Pakistan.

(b) In the case of Goods of foreign origin offered from abroad, customs duties, sales tax and other import charges which will be payable on furnished Goods in Pakistan.

(c) In the case of Goods of foreign origin already located in Pakistan, customs duty, sales tax and import charges on CIF price as applicable for Sub-Clause 29.4(b) here above.

29.5 The price preference to Group A bids will be:

- (i) 15% of the ex-factory bid price, if the value addition through indigenous manufacturing is at least 20%;
- (ii) 20% of the ex-factory bid price, if the value addition through indigenous manufacturing is over 20% and up to 30%; and
- (iii) 25% of the ex-factory bid price, if the value addition through indigenous manufacturing is over 30%.

29.6 The applicable price preference i.e., as per Sub-Clause 29.5 here above will be applied to Group A Bid by reducing the ex-factory bid price.

Process to be  
Confidential

30.1 Subject to Clause 25 heretofore, no Bidder shall contact Employer and/or Engineer on any matter relating to its Bid from the time of the Bid opening to the time the bid evaluation result is announced by the Employer. However the eligibility of each bidder will be examined in light of the employer's mandatory requirements to be furnished by each bidder in his technical proposal i.e bidder experience of similar works, personal capabilities etc: .

30.2 Any effort by a Bidder to influence Employer and/or Engineer in the Bid evaluation, Bid comparison or Contract Award decisions may result in the rejection of his Bid. Whereas any bidder feeling aggrieved may lodge a written complaint not later than fifteen (15) days after the announcement of the bid evaluation result; however, mere fact of lodging a complaint shall not warrant suspension of the procurement process.

**F. AWARD OF CONTRACT**

Post-Qualification

31.1 The Employer, at any stage of the bid evaluation, having credible reasons for or prima facie evidence of any defect in supplier's or contractor's capacities, may require the suppliers or contractors to provide information concerning their professional, technical, financial, legal or managerial competence whether already pre-qualified or not:

Provided that such qualification shall only be laid down after recording reasons there for in writing. They shall form part of the records of that bid evaluation report.

31.2 The determination will take into account the bidder's financial, technical and production capabilities. It will be based upon an examination of the documentary evidence of the bidder's qualification submitted under Annexure-B to Bidding Data "Evidence of Bidder's Eligibility and Qualifications" by the bidder pursuant to Clause IB.15, as well as such other information as required under the Bidding Documents.

31.3 An affirmative determination will be a pre-requisite for award of the Contract to the lowest evaluated bidder. A negative determination will result in rejection of that bidder's bid in which event, Employer will proceed to undertake a similar determination of the next lowest evaluated bidder's capabilities to perform the Contract satisfactorily.

Award Criteria

32.1 Subject to Clause IB.34, the Employer will award the Contract to the bidder whose bid has been determined to be substantially responsive to the Bidding Documents and who has offered the lowest evaluated Bid Price, provided that such bidder has been determined to be qualified to satisfactorily perform the Contract in accordance with the



		provisions of Clause IB.31.
Employer's Right to Vary Quantities	33.1	Employer reserves the right at the time of award of Contract to increase or decrease by upto 15% the quantity of goods and services specified in the Bill of Quantities without any change in the unit price or other terms and conditions.
Employer's Right to Accept any Bid and to Reject any or all Bids	34.1	Notwithstanding Clause IB.32, the Employer reserves the right to accept or reject any bid, and to annul the bidding process and reject all bids, at any time prior to award of Contract, without thereby incurring any liability to the affected bidders or any obligation to inform the affected bidders of the grounds for the Employer's action except that the grounds for its rejection shall upon request be communicated, to any bidder who submitted a bid, without justification of grounds. Rejection of all bids shall be notified to all bidders promptly.
	34.2	No negotiations with the bidder having been evaluated as lowest responsive or any other bidder shall be permitted. However, the Employer may have clarification meeting(s) to get clarify any item(s) in the bid evaluation report
Notification of Award	35.1	Prior to expiration of the period of bid validity prescribed by the Employer, the Employer will notify the successful bidder in writing ("Letter of Acceptance") that his Bid has been accepted. This letter shall name the sum which the Employer will pay the Contractor in consideration of the execution and completion of the Works by the Contractor as prescribed by the Contract (hereinafter and in the Conditions of Contract called the "Contract Price").
	35.2	The Letter of Acceptance and its acceptance by the bidder will constitute the formation of the Contract, binding the Employer and the Bidder till signing of the formal Contract Agreement.
	35.3	Upon furnishing by the successful bidder of a Performance Security, the Employer will promptly notify the other bidders that their bids have been unsuccessful and return their bid securities.
Performance Security	36.1	The successful bidder shall furnish to the Employer a Performance Security in the form and the amount stipulated in the Bidding Data and the Conditions of Contract within a period of 28 days after the receipt of Letter of Acceptance.
	36.2	Failure of the successful bidder to comply with the requirements of Sub-Clause IB.36.1 or Clause IB.37 or Clause IB.44 shall constitute sufficient grounds for the annulment of the award and forfeiture of the Bid Security.
Signing of Contract Agreement	37.1	Within 14 days from the date of furnishing of acceptable Performance Security, the Employer will send the successful bidder the Contract Agreement in the form provided in the Bidding Documents, incorporating all agreements between the parties.
	37.2	The formal Agreement between the Employer and the successful bidder shall be executed within 14 days of the receipt of the Contract Agreement by the successful bidder from the Employer.

#### **G. ADDITIONAL INSTRUCTIONS**

Instructions not Part of Contract	38.1	Bids shall be prepared and submitted in accordance with these Instructions which are provided to assist bidders in preparing their bids, and do not constitute part of the Bid or
-----------------------------------	------	---

		the Contract Documents.
Contract Documents	39.1	The Documents which will be included in the Contract are listed in the Form of Contract Agreement set out in these Bidding Documents
Sufficiency of Bid	40.1	Each bidder shall satisfy himself before Bidding as to the correctness and sufficiency of his Bid and of the rates and prices entered in the Bill of Quantities. Except insofar as it is otherwise expressly provided in the Contract, the rates and prices entered in the Bill of Quantities shall cover all his obligations under the Contract and all matters necessary for the proper completion of the Works.
Bidder to Inform Himself	41.1	The bidder is advised to obtain for himself at his own cost and responsibility all information that may be necessary for preparing the bid and entering into a Contract for execution of the Works. This shall include but not be limited to the following: <ul style="list-style-type: none"> <li>(a) inquiries on Pakistani Income Tax/Withholding Tax/ Sales Tax, Federal and Provincial.</li> <li>(b) inquiries on customs duties and other import taxes, to the concerned authorities of Customs and Excise Department.</li> <li>(c) information regarding opening of Letter of Credits, port clearance facilities, loading and unloading facilities, storage facilities, transportation facilities and congestion at Pakistan seaports and the respective cost to be born by him and that is deemed to be included in the bid offered by him.</li> <li>(d) investigations regarding transport conditions and the probable conditions which will exist at the time the Goods will be actually transported.</li> </ul>
Alternate Proposals by Bidder	42.1	Should any bidder consider that he can offer any advantage to the Employer by a modification to the designs, specifications or other conditions, he may, in addition to his bid to be submitted in strict compliance with the Bidding Documents, submit any Alternate Proposal(s) containing (a) relevant design calculations; (b) technical specifications; (c) proposed construction methodology; and (d) any other relevant details / conditions, provided always that the total sum entered on the Letter of Bid shall be that which represents complete compliance with the Bidding Documents.
	42.2	Alternate Proposal(s), if any, of the lowest evaluated responsive bidder only may be considered by the Employer as the basis for the award of Contract to such bidder.
Local Conditions	43.1	Bidder must verify and supplement by his own investigations the information about site and local conditions. However, Employer will assist the Bidder wherever practicable and possible
Integrity Pact	44.1	The Bidder shall sign and stamp the Integrity Pact provided at Appendix-K to Bid in the Bidding Documents for all Federal Government procurement contracts exceeding Rupees ten million. Failure to provide such Integrity Pact shall make the bidder non-responsive.

## **BIDDING DATA**

### BIDDING DATA

*[The following specific data for the works to be bid shall complement, amend, or supplement the provisions in relation to corresponding clauses in the Instructions to Bidders and to suit each individual contract; as such the Instructions to Bidders will remain unchanged. Wherever there is a conflict, the provisions herein shall prevail over those in the Instructions to Bidders.*

*Instructions are provided, as needed, in italics.*

IB Clause Reference	Bidding Data
1.1	Name and address of the Employer: <i>Executive Engineer Swabi Irrigation Division-II Swabi Office of Executive Engineer Swabi Irrigation Division-II Swabi Telephone/Fax No 0938-920031, Email: <a href="mailto:xen2swabi@yahoo.com">xen2swabi@yahoo.com</a></i>
1.1	Name of the Project & Summary of the Works: <b><i>As per Notice Inviting E-bidding</i></b>
2.1	Name of the Borrower/Source of Financing/Funding Agency: <i>Provincial ADP through Govt of Khyber Pakhtunkhwa</i>
2.1	Amount and type of financing: <i>As per BOQ</i>
3.1 (a)	Bidders shall be duly Licensed by the Pakistan Engineering Council (PEC), relevant to the Works in the category: <i>C-6 &amp; Above with Code of Specialization of CE-04, CE-09&amp; EE-11</i> In the case of JV of firms, number of Partners shall not be more than <u>2</u> Foreign firms may form JV with Local firms having share not less than 30%.
3.1(b)	Bidder's Country: <i>[Eligible countries listed in Annexure-A to Bidding Data]</i>
3.1(c)	<i>NA; Any Firm can apply having the required qualifications. Post Qualifications method of procurement is applicable.</i>
5.1	<i>[Goods and ancillary Services to be supplied under this Contract shall have their origin in eligible countries listed in Annexure-A to Bidding Data]</i>
8.1	a) <i>Executive Engineer Swabi Irrigation Division-II Swabi Office of Executive Engineer Swabi Irrigation Division-II Swabi Telephone/Fax No 0938-920031, Email: <a href="mailto:xen2swabi@yahoo.com">xen2swabi@yahoo.com</a></i> b) <i>Executive Engineer Swabi Irrigation Division-II Swabi Office of Executive Engineer Swabi Irrigation Division-II Swabi Telephone/Fax No 0938-920031, Time limit for clarification: 7 days</i>
IB Clause Reference	Bidding Data
8.2	Venue, time, and date of the pre-Bid meeting: <i>Executive Engineer Swabi Irrigation Division-II Swabi Office of Executive Engineer Swabi Irrigation Division-II Swabi Telephone/Fax No 0938-920031 on 04/4/2022</i>
10.1	Bid language: <i>English</i>
11.1(j)	<i>[The particulars for domestic Goods prescribed in Annexure-C to Bidding Data]</i>
15.4 (a)	Bidder/Manufacturer's Experience: <i>03 Years</i> Plant should have produced required items for at least 03 years. Those items have proven successful in the field for at least 02 years. <i>[The bidder shall furnish documentary evidence of qualification in accordance with Annexure-B to Bidding Data]</i>
17.1	Amount of Bid Security + Stamp Duty: <i>Rs</i>

<b>18.1</b>	Period of Bid Validity: <i>90 days</i>
<b>19.4</b>	Number of copies of the Bid to be completed and returned: <i>01 Original + 01 Copy</i>
<b>21.1(a)</b>	Employer's address for the purpose of Bid submission: <i>Office of Executive Engineer Swabi Irrigation Division-II Swabi</i> <i>Telephone/Fax No 0938-920031, Email: <a href="mailto:xen2swabi@yahoo.com">xen2swabi@yahoo.com</a></i> Deadline for submission of bids: <i>12:00 Noon; 12/4/2022</i>
<b>24.1</b>	Venue, time, and date of Bid opening: <i>Office of Executive Engineer Swabi Irrigation Division-II Swabi</i> <i>Telephone/Fax No 0938-920031, Email: <a href="mailto:xen2swabi@yahoo.com">xen2swabi@yahoo.com</a></i> <i>12:30 PM; 12/4/2022</i>
<b>31.2</b>	<i>[The documentary evidence of the bidder's qualification shall be as per Annexure-B to Bidding Data]</i>
<b>IB Clause Reference</b>	<b>Bidding Data</b>
<b>36.1</b>	Standard form and amount of Performance Security acceptable to the Employer: <i>10% of the Contract Cost Bank Guarantee</i>

# **ANNEXURE TO BIDDING DATA**

**Annexure-A to Bidding Data**

**NAME OF ELIGIBLE COUNTRIES**

*[User to list down the Name of eligible countries as per Clause 2 of Instructions to Bidders]*

## Annexure-B to Bidding Data

### EVIDENCE OF BIDDER'S ELIGIBILITY AND QUALIFICATION

*[Note: Bidders to provide the following information with the bid separately and indicate herein its references where this information is available.]*

Sr.No.	Information to be Supplied	Bid References
1.	Name of bidder, business address and country of incorporation.	Annexure-B1 Bidder Information Sheet
2.	Type of firm whether individually owned, partnership, corporation or joint venture and the names of its owners or partners	Annexure-B2 Party to JV Information Sheet
3.	Copy of PEC license in the appropriate relevant category relevant to the value of the Works	
4.	Copy of the NTN and Sale Tax Registration and Income Tax Return for the last three (3) years	
5.	The annual reports or qualification statements giving general description of the firm, sort of business carried out, balance sheets, profit and loss statements, turn over and business done by the firm, duly authenticated, for the last five (5) years. Audited Balance Sheets for the preceding 3 years and projected assets and liabilities for the next 2 years shall be provided.	Annexure-B3 Financial Situation, Annexure-B4 Average Annual Construction Turnover, Annexure-B5 Financial Resources , Audit Report and others
6.	Location and address of manufacturing facilities.	
7.	Full description of factories owned and the annual manufacturing capacities of various items made therein.	
8.	Details of the factory or factories where the offered equipment is proposed to be manufactured. This description should include the facilities and capacities of the particular factories including testing facilities and the processes used in manufacturing and testing. Where parts or components are purchased from outside, the details of equipment purchased and the names and experience record of the suppliers.	
9.	Detailed description of the quality control testing and research facilities. If the equipment is manufactured under license, the name of the licensor and details of the licensing arrangements, such as the duration of the license, the facilities provided to the bidder by the licensor and whether future improvements are available or not etc. A copy of the license agreement may be attached.	
Sr.No.	Information to be Supplied	Bid References
10.	In the case of a bidder offering to supply Goods under the Contract which the bidder did not manufacture or otherwise produce, the bidder has been duly authorized by the Goods manufacturer or producer to supply the Goods to Pakistan. In such case The Bidder/Supplier shall require the Manufacturer to fill in the Authorization letter.	Annexure-B6 Manufacturer's Authorization Letter
11.	Names, qualifications and experience of the key technical personnel. The Bidder must demonstrate that it will have the	Annexure-B7 Key Personnel & Annexure-B8 Resume of Key Personnel



	<p>personnel for the key positions that meet the following requirements:</p> <table border="1"> <thead> <tr> <th>No.</th> <th>Position</th> <th>Total Work Similar Experience (years)</th> <th>In Similar Works Experience (years)</th> </tr> </thead> <tbody> <tr> <td>1.</td> <td></td> <td></td> <td></td> </tr> <tr> <td>2.</td> <td></td> <td></td> <td></td> </tr> <tr> <td>3.</td> <td></td> <td></td> <td></td> </tr> <tr> <td>...</td> <td></td> <td></td> <td></td> </tr> </tbody> </table> <p>The Bidder shall provide details of the proposed personnel and their experience records in the given Annexure.</p>	No.	Position	Total Work Similar Experience (years)	In Similar Works Experience (years)	1.				2.				3.				...				
No.	Position	Total Work Similar Experience (years)	In Similar Works Experience (years)																			
1.																						
2.																						
3.																						
...																						
12.	The time since the manufacturer has been in this business and the time since he has been doing work of similar nature.																					
13.	<p>The time since the particular equipment offered has been manufactured and the time for which it has been in service. The manufacturer shall have the following experience;</p> <hr/> <p><i>[List the equipment and experience required]</i></p> <p>The Bidder must demonstrate that it will have access to the key Contractor's equipment listed hereafter:</p> <table border="1"> <thead> <tr> <th>No.</th> <th>Equipment Type and Characteristics</th> <th>Minimum Number required</th> </tr> </thead> <tbody> <tr> <td>1.</td> <td></td> <td></td> </tr> <tr> <td>2.</td> <td></td> <td></td> </tr> <tr> <td>3.</td> <td></td> <td></td> </tr> <tr> <td>...</td> <td></td> <td></td> </tr> </tbody> </table> <p>The Bidder shall provide further details of proposed items of equipment using the relevant Annexure.</p>	No.	Equipment Type and Characteristics	Minimum Number required	1.			2.			3.			...			Annexure-9 Contractor's Equipment					
No.	Equipment Type and Characteristics	Minimum Number required																				
1.																						
2.																						
3.																						
...																						
<b>Sr.No.</b>	<b>Information to be Supplied</b>	<b>Bid References</b>																				
14.	Reference lists of similar works done by the bidder in its country and abroad indicating the name of customer, description and quantity of product, year of supply installation and the approximate value.	Annexure-10 General Experience & Annexure-11 Specific Experience																				
15.	Details of projects under execution and future contractual commitments (for each partner, in case of a joint venture).	Annexure-12 Current Contract Commitments																				
16.	Banking reference, names of banks and addresses may be given to whom reference regarding financial capability of the bidder may be made, with authority to make inquiries from the bidder's bankers and clients regarding any financial and technical aspects (for each partner, in case of a joint venture).																					
17.	Information on any litigation or arbitration resulting from contracts completed or under execution by the bidder over the last ten (10) years. The information shall indicate the parties concerned, the matter of dispute, the disputed amounts and the result thereof (for each partner, in case of a joint venture).	Annexure-13 Pending Litigation																				

## Application Form A – 1

### General Information

*All individual firms and each partner of a joint venture applying for qualification are requested to complete the information in this form. Nationality information is also to be provided for foreign owners or applicants who are forming part of the Joint Ventures as required under the PEC Bye-Laws as a Partnership/Joint Venture.*

*Where the Applicant proposes to use named subcontractors for critical components of the works or for work contents in excess of 10 percent of the value of the whole works, the following information should also be supplied for the specialist subcontractor(s).*

1.	Name of Firm	
2.	Head Office Address	
3.	Telephone	Contact Person: Name: Title:
4.	Fax	
5.	Place of Incorporation/Registration	Year of Incorporation/Registration

<b>NATIONALITY OF OWNERS</b>		
	<b>NAME</b>	<b>NATIONALITY</b>
1.		
2.		
3.		
4.		
5.		

**Application Form A – 2****General Experience Record**

Name of Applicant or partner of a joint venture
---

*All individual firms and all partners of a joint venture are requested to complete the information in this form. The information supplied should be the annual turnover of the Applicant (or each member of a joint venture), in terms of the amounts billed to clients for each year for work in progress or completed over the past five years.*

*Use a separate sheet for each partner of a joint venture.*

<b>Annual Turnover</b>		
<b>Year</b>	<b>Turnover (in actual currency)</b>	<b>Equivalent Rupees in Millions</b>
1.		
2.		
3.		
4.		
5.		

Page \_\_\_ of \_\_\_ Pages

**Application Form A - 3****Joint Venture Summary**

<b>Names of all Partners of a Joint Venture</b>	
Lead Partner	
Partner	
3. Partner	

*Total value of annual turnover, in terms of work billed to clients,*

<b>Annual Turnover Data (Equivalent in Pak Rupees, Millions)</b>						
<b>Partner</b>	<b>Form A-2 Page No.</b>	<b>Year 1</b>	<b>Year 2</b>	<b>Year 3</b>	<b>Year 4</b>	<b>Year 5</b>
1. Lead Partner						
2. Partner						
3. Partner						
<b>Total:</b>						

## Application Form A – 4

### Particular Experience Record

*Name of Applicant or partner of a joint venture*

*On a separate page, using the format of Application Form A-5, each applicant or partner of a Joint Venture is required to list all contracts of a value equivalent to Pak **50%** of the tender cost (Two certificates only) of the contract for which applicant wishes to qualify.*

*Where the Applicant proposes to use named subcontractor(s) for critical components of the works or for work contents in excess of 10 percent of the value of the whole works, the information in the afore-mentioned forms should also be supplied for each specialist subcontractor.*

Page \_\_\_ of \_\_\_ Pages

### Application Form A – 5 Details of Contracts of Similar Nature & Complexity

*Name of Applicant or partner of a joint venture*

Use a separate sheet for each contract.

1.	Name of Contract
	Country
2.	Name of Employer
3.	Employer Address.....
4.	Nature of works and special features relevant to the contract for which the Applicant wishes to pre-qualify ..... .. ..... ..
5.	Contract Role (Tick One) (a) Sole Contractor      (b) Sub- Contractor      (c) Partner in a Joint Venture
6.	Value of the total contract (in specified currencies) at completion, or at date of award for current contract  Currency .....      Currency .....      Currency .....
7.	Equivalent in Pak/Rs.
8.	Date of Award
9.	Date of Completion
10.	Contract Duration (Years and Months)  _____ Years      _____ Months
11.	Specified Requirements <sup>1</sup> ..... ..... .....

<sup>1</sup>Insert any specific criteria required for particular operations, such as annual volume of earthmoving, underground excavation, or placing concrete etc.  
All the completions be certified by the respective employers

**Application Form A – 6****Summary Sheet: Current Contract Commitments/Works in Progress**

<i>Name of Applicant or partner of a joint venture</i>
--

*Applicants and each partner to an application should provide information on their current commitments on all contracts that have been awarded, or for which a letter of intent or acceptance has been received, or for contracts approaching completion, but for which substantial Completion Certificate has yet to be issued.*

<b>Name of Contract</b>	<b>Value of Outstanding work (Equivalent Pak Rs. Millions)</b>	<b>Estimated Completion Date</b>
1.		
2.		
3.		
4.		
5.		
6.		

The information be supported duly attested certificates of the concerned employers

Page \_\_\_ of \_\_\_ Pages

**Application Form A – 7****Personnel Capabilities**

<i>Name of Applicant</i>
--------------------------

*For specific positions essential to contract implementation, Applicants should provide the names of at least two candidates qualified to meet the specified requirements stated for each position. The data on their experience should be supplied on separate sheets using one Form for each candidate (Application Form A-8).*

1.	Title of Position
	Name of Prime Candidate with cell No.
	Name of Alternate Candidate with cell No.
2.	Title of Position
	Name of Prime Candidate with cell No.
	Name of Alternate Candidate with cell No.
3.	Title of Position
	Name of Prime Candidate with cell No.
	Name of Alternate Candidate with cell No.
4.	Title of Position
	Name of Prime Candidate with cell No.
	Name of Alternate Candidate with cell No.



**Application Form A – 8**

**Candidate Summary**

*Name of Applicant*

<b>Position</b>		<b>Candidate</b> [Tick appropriate one]  <input type="checkbox"/> Prime <input type="checkbox"/> Alternate
Candidate information	Name of Candidate	Date of Birth
	Professional Qualification	4. PEC Registration No.
Present employment	5. Name of employer	
	Address of employer	
	Telephone	Contact (manager/personnel officer)
	Fax	
	Job title of candidate	Years with present employer

*Summarize professional experience over the last 10 years, in reverse chronological order. Indicate particular technical and managerial experience relevant to the Project.*

<b>Month/ Dates/Years</b>		<b>Company/Project/Position/Relevant technical and management experience</b>
<b>From</b>	<b>To</b>	

Page \_\_\_ of \_\_\_ Pages

## Application Form A - 9 Equipment Capabilities

<i>Name of Applicant</i>
--------------------------

*The Applicant shall provide adequate information to demonstrate clearly that he has the capability to meet the requirements for each and all items of equipment listed in the Evaluation Criteria 1.2 (v). A separate Form shall be prepared for each item of equipment listed or for alternative equipment proposed by the Applicant.*

<b>Item of Equipment</b>		
Equipment information	Name of manufacturer	Model and power rating
	Capacity	Year of manufacture
Current status	Current location	
	Details of current commitments	
Source	Indicate source of the equipment  <input type="checkbox"/> Leased	

*Omit the following information if it is owned by the Applicant or partner.*

Owner	Name of owner	
	9. Address of owner	
	Telephone	Contact name and title
	Fax	
Agreement	Details of rental/lease specific to the Project	

## Application Form A - 10 Financial Capability

### ***Name of Applicant or Partner of a Joint Venture***

Applicants, including each partner of a joint venture, should provide financial information to demonstrate that they meet the minimum requirements that the lead partner shall meet not less than 40 percent of all qualifying criteria and each of the partners shall meet not less than 25 percent of all the qualifying criteria given in Evaluation Criteria. All the above figures will be added together to arrive at JV's total capacity. Each applicant or partner of a joint venture must fill-in this form. If necessary, use separate sheets to provide complete banker information. A copy of the audited balance sheets should be attached.

<b>Banker</b>	Name of banker	
	Address of banker	
	Telephone	Contact name and title
	Fax	Telex

Summarize actual assets and liabilities in Pak Rupees (Equivalent at the current rate of exchange at the end of each year) for the previous five years, based upon known commitments, projected assets and liabilities in pak Rupees equivalent for the next two years.

Financial information in Pak Rs. or equivalent	Actual: previous five year					Projected next two years	
	1	2	3	4	5	6	7
Total assets							
Current assets							
Total liabilities							
Current liabilities							
Profits before taxes							
Profits after taxes							

Specific proposed sources of financing to meet the cash flow of the Project, net of current commitments

Source of financing	Amount (Pak Rs. or equivalent)
1.	
2.	
3.	
4.	

Attach audited financial statements for the last five years (for individual applicant or each partner of joint venture). Firms owned by individuals, and partnerships, may submit their balance sheets certified by a registered accountant, and supported by copies of tax returns, if audits are not required by the laws of their countries of origin in case of foreign firms.



## Check List for Mandatory documents

Yes	No	Check list
<input type="checkbox"/>	<input type="checkbox"/>	Valid PEC Certificate(s) in required category
<input type="checkbox"/>	<input type="checkbox"/>	Copy of valid dealer ship certificate
<input type="checkbox"/>	<input type="checkbox"/>	Application form (A-1), General Information
<input type="checkbox"/>	<input type="checkbox"/>	Application form (A-2), General Experience Record
<input type="checkbox"/>	<input type="checkbox"/>	Application form (A-3), Joint Venture Summary
<input type="checkbox"/>	<input type="checkbox"/>	Application form (A-4), Particular Experience (Record List of Solar based pumping machinery projects of similar nature and complexity completed in last five years and complexity in-hand.)
<input type="checkbox"/>	<input type="checkbox"/>	Application form (A-5), Detail of Contracts of Similar Nature and Complexity (Supply & Installation of Solar based pumping machinery)
<input type="checkbox"/>	<input type="checkbox"/>	Application form (A-6) Current Contract Commitments/Works in Progress
<input type="checkbox"/>	<input type="checkbox"/>	Application form (A-7), Personnel Capabilities
<input type="checkbox"/>	<input type="checkbox"/>	Application form (A-8) Candidate Summary (List of B.Sc. Engineers having relevant experience with their CVs and PEC Reg. No.& List of Associates Engineers (DAE) with their CVs having relevant experience )
<input type="checkbox"/>	<input type="checkbox"/>	Application form (A-9), Equipment capabilities
<input type="checkbox"/>	<input type="checkbox"/>	Application form (A-10), Financial Capability
<input type="checkbox"/>	<input type="checkbox"/>	Application form (A-11), Litigation History
<input type="checkbox"/>	<input type="checkbox"/>	Undertaking that all equipment listed in this document for qualification will be made available for the subject Project
<input type="checkbox"/>	<input type="checkbox"/>	Audited balance sheets for at least last three years and Bank statements
<input type="checkbox"/>	<input type="checkbox"/>	Undertaking that the Applicant has not been declared bankrupt
<input type="checkbox"/>	<input type="checkbox"/>	Original affidavit that the firm has not been black listed
<input type="checkbox"/>	<input type="checkbox"/>	Applicants legal status
<input type="checkbox"/>	<input type="checkbox"/>	Principal place of Business
<input type="checkbox"/>	<input type="checkbox"/>	Place of incorporation or registration
<input type="checkbox"/>	<input type="checkbox"/>	Certificate of registration with Income Tax & Sales Tax Department
<input type="checkbox"/>	<input type="checkbox"/>	Enlistment record with Government organizations and other agencies
<input type="checkbox"/>	<input type="checkbox"/>	Location of workshop facility, if any
<input type="checkbox"/>	<input type="checkbox"/>	Equipment's sole agencies represented by the Contractor
<input type="checkbox"/>	<input type="checkbox"/>	Written description of internal quality control program for specified works

## EVALUATION CRITERIA

### 1.1 Eligibility for Qualification

Keeping in view the complexity of the Project, eligibility of Applicants for qualification evaluation is as mentioned below:

Sr. No.	Description	Yes/No
1.	Registration with Pakistan Engineering Council (PEC) in relevant category C-6 with field of specialization EE-04 & EE-11 CE-09 <b>(Specified for Solar Energy)</b>	If "YES" the applicant will be Eligible for further Evaluation for qualification (copy of valid PEC certificate shall be attached).
2.	Blacklisting from any Government/Semi-Government Agency/Department.	If "YES" the applicant will not be Eligible for further Evaluation for qualification. (Original Affidavit on Judicial Stamp Paper that the firm has not been black listed from any Government/ Semi Government Agency/ Department till date shall be provided).
3.	<p>Firm must have ISO 9001-2008 certificate quality management system</p> <p>Warranty period for solar panel etc will be 20 years and Defect Liability Period for electrical /mechanical works will be 2 years.</p> <p>The Firm must have an average annual turnover in the last 5 years equal to or more than the Total Bid Price. Alternately, the bidder should have successfully completed in the last five years any specific project having value equal to or higher than the total Bid Price. Documentary proof must be attached in support with the average annual turnover.</p> <p>Goods declaration (bill of entry) must be provided for each product (i.e Solar Panel, Pumps, Motors, Inverter).</p> <p>Performance curves at STC for both solar panel and pumping machinery should be provided for each work separately along with bidding documents</p> <p>The PV modules offered should not be more than One (01) year old with respect to the date of manufacturing.</p> <p>Brand name(s) of PV modules, the supplier intends to supply must be included in the technical proposal.</p>	Attach Valid documents

## 1.2 Evaluation Criteria

Keeping in view the complexity of the Project works, criteria for qualification has been evolved by considering the prevailing market trends as mentioned below:

<b>Sr. No.</b>	<b>Category</b>	<b>Weightage/Marks</b>
i.	General Capabilities	10
ii.	Financial Soundness	20
iii.	Experience Record	30
iv.	Personnel Capabilities	20
v.	Equipment Capabilities	20
Total:		100

Qualification will be carried out on the point scoring basis. Any applicant securing overall minimum score of 60 % as total will be considered as qualified.

An applicant may score below 60% in any one category provided it is not less than 50%.

Applicants having score of less than 60% in any two categories shall not be considered for further evaluation.

The employer reserves the right to proceed against the bidder who has provided fake information/documents which may result in his blacklisting after approved by the competent authorities.

## Qualification Evaluation Criteria

### i) General Capabilities

a)	Copy of Valid dealer ship(pumps & solar panels) certificate from Sub-Contractor/JV Partner	2	No marks will be given if license is not attached and 2 points will be added in case of valid certificate.
b)	Litigation History in which Decision has been given against the firm(s)	6	In case the firm is involved in any litigation, -5 will be given and 6 points will be added in case original affidavit of no litigation is attached.
c)	Description of Internal Quality Control assurance program for Construction/ Erection/Maintenance	2	2 Marks will be given if Description is provided.
<b>Total Marks Allocated</b>			<b>10</b>

### ii) Financial Soundness

Sr. No.	Description	Marks Assigned	Criteria for Marks Obtained
a)	Bank Certificate including Bank Credit Line (Evidence in Original from Guarantor Bank)	5	<p><b><u>Bank Certificate (2-Marks)</u></b></p> <p>2 Marks are given if Original Bank Certificate is provided.</p> <p><b><u>Bank Credit Line (3-Marks)</u></b></p> <p>2 Marks are given if the available bank credit line limit is equal to 10 Million.</p> <p>For limit less than 10 Million, use following weight-age:</p> <p><math>2 \times (A/15)</math></p> <p>For the limit more than 10 million but less than 20 million use following weight-age:</p> <p><math>2 + (A/30)</math></p> <p>A = Available Bank Credit Line Limit</p> <p>Full Marks are given in case of limit is 20 million or more.</p>



b)	Audited Balance Sheets for at least last two years	5	No marks will be given if Audited Balance Sheets are not attached. Two (2) points will be given for one year audited balance sheets, four (4) points for two years and full points for three years.
c)	Working Capital in last 03 years	5	<p>3 Marks are given if the available average working capital for last three years is equal to 10 Million.</p> <p>For the capital less than 10 million use following weight-age:</p> $3 \times (A/15)$ <p>For the capital more than 10 million but less than 20 million use following weight-age.</p> $3 + (A/30)$ <p>A = Average working capital in last three years.</p> <p>Full Marks are given in case of limit is 20 million or more.</p>
d)		5	No marks will be given if NTN & GST Registration certificate is not attached and 5 points will be added in case of valid certificates.
<b>Total Marks Allocated</b>			<b>20</b>

## iii) Experience Record

Sr. No.	Description	Marks Assigned	Explanation for Marks Obtained
a)	Projects of similar nature and complexity (Supply & Installation of Solar Based Pumping Machinery) completed in last five years in any Public Works Department/NGOs.	16	<p>8 Marks are given if the applicant has completed at least 5 projects of similar nature in last five years.</p> <p>For less than 5 projects completed use the following weight age.</p> <p><math>8 \times (A/5)</math></p> <p>For more than 5 projects but less than 10 projects completed use the following weight age.</p> <p><math>8 + (A/5) \times 4</math></p> <p>A = No of projects of similar nature completed in last five years</p> <p>Full Marks are given in case of 10 projects or more.</p>
b)	Projects of similar nature and complexity (Supply & Installation of Solar Based Pumping Machinery) in-hand in any Public Works Department/NGOs.	9	<p>4 Marks are given if the applicant has completed at least 5 projects of similar nature in last five years.</p> <p>For less than 5 projects completed use the following weight age.</p> <p><math>4 \times (A/5)</math></p> <p>For more than 5 projects but less than 10 projects completed use the following weight age.</p> <p><math>4 + (A/10) \times 4</math></p> <p>A = No of projects of similar nature completed in last five years</p> <p>Full Marks are given in case of 10 projects or more.</p>
c)	Enlistment record with Government Organizations & other agencies	5	1 Mark for each enlistment up to maximum of five enlistments.
<b>Total Marks Allocated</b>			<b>30</b>

iv) **Personnel Capabilities**

<b>Sr. No.</b>	<b>Description</b>	<b>Marks Assigned</b>	<b>Explanation for Marks Obtained</b>
i)	B.Sc. Engineers registered with Pakistan Engineering Council (PEC)	14	<p><b><u>Experience (6-Marks)</u></b></p> <p>6 Marks will be given if the individual relevant experience of at least 1 numbers of B.Sc. Engineer Electrical/Electronics /Mechanical (professional) is equal to 15 years or above.</p> <p>3 Marks will be given if experience is more than 3 years and less than 15 years</p> <p><b><u>Strength of Engineers (8 Marks)</u></b></p> <p>4 Marks will be given if the total no. of Engineers registered with PEC is 3.</p> <p>8 Marks will be given if the total no. of engineers registered with PEC is 5 or above.</p>
ii)	Associates Engineers (DAE)	6	<p><b><u>Experience (4-Marks)</u></b></p> <p>4 Marks will be given if the individual relevant experience of at least 1 number of Associates Engineers Electrical/Mechanical (DAE) is equal to 8 years or above.</p> <p><b><u>Strength of Associate Engineers (2 Marks)</u></b></p> <p>2 Marks will be given if the total no. of Associate Engineers (DAE) are 3 or above.</p>
<b>Total Marks Allocated</b>			<b>20</b>

**v) Equipment Capabilities**

<b>Sr. No.</b>	<b>Description</b>	<b>Marks Assigned</b>	<b>Explanation for Marks Obtained</b>
a)	1. Test Bed for verification / testing of Solar pumps along with all accessories as per ISO-9906 in company premises. (Firm must have Third Party Certification regarding Test Bed arrangements).	13	13 Marks for complete setup are given. (Attached Third Party Certificate)
b)	Workshop facilities. Attach layout sketch of workshop.	5	No marks will be given if Contractor has no workshop facilities.
c)	Equipment sole agencies represented by the Contractor	2	1 mark for each agency Upto maximum 2 points
<b>Total Marks Allocated</b>			<b>20</b>

**Appendix C to  
Instructions to Bidders**

**Domestic Goods (Value added in Pakistan)**

NOT USED

**BIDDER INFORMATION SHEET**

Date: \_\_\_\_\_  
 ICB No.: \_\_\_\_\_  
 Page \_\_\_ of \_\_\_ pages

<b>Bidder's Information</b>	
<b>Bidder's Legal Name:</b>	
<b>In case of JV, legal name of each party:</b>	
<b>Bidder's actual or intended Country of Registration:</b>	
<b>Bidder's Year of Registration:</b>	
<b>Bidder's Legal Address in Country of Registration:</b>	
<b>Bidder's Authorized Representative Information</b> Name: Address:  Telephone/Fax numbers: Email Address:	
<p><b>Attached are copies of the original documents:</b>            Articles of Incorporation or Registration of firm named in 1, above.            In case of JV, letter of intent to form JV including a draft agreement, or JV agreement.            In case of government owned entity from the Employer's country, documents establishing legal and financial autonomy and compliance with the principles of commercial law.</p>	

**Annexure-B2****PARTY TO JV INFORMATION SHEET**

Date: \_\_\_\_\_  
 ICB No.: \_\_\_\_\_  
 Page \_\_\_ of \_\_\_ pages

*[Each member of a JV must fill in this form]*

<b>JV Information</b>	
<b>. Bidder's legal name</b>	
<b>. JV Partner's legal name</b>	
<b>. JV Partner's country of constitution</b>	
<b>. JV Partner's year of constitution</b>	
<b>. JV Partner's legal address in country of constitution</b>	
<b>. JV Partner's authorized representative information</b> Name: Address:  Telephone/Fax numbers: Email Address:	
<b>7. Attached are copies of the following original documents.</b> <ul style="list-style-type: none"> <li>▪ Articles of incorporation or constitution of the legal entity named above.</li> <li>▪ Authorization to represent the firm named above.</li> <li>▪ In the case of government-owned entity, documents establishing legal and financial autonomy and compliance with commercial law.</li> </ul>	

## FINANCIAL SITUATION

Bidder's Legal Name: \_\_\_\_\_  
 JV Partner Legal Name: \_\_\_\_\_

Date: \_\_\_\_\_  
 ICB No.: \_\_\_\_\_  
 Page \_\_\_ of \_\_\_ pages

*[Each Bidder or member of a JV must fill in this form]*

Financial Data for Last 3 Years [Pak Rs Equivalent]		
Year 1:	Year 2:	Year 3:

## Information from Balance Sheet

<b>Total Assets</b>			
<b>Total Liabilities</b>			
<b>Net Worth</b>			
<b>Current Assets</b>			
<b>Current Liabilities</b>			

## Information from Income Statement

<b>Total Revenues</b>			
<b>Profits Before Taxes</b>			
<b>Profits After Taxes</b>			

- Attached are copies of financial statements (balance sheets including all related notes, and income statements) for the last three years, as indicated above, complying with the following conditions.
  - All such documents reflect the financial situation of the Bidder or partner to a JV, and not sister or parent companies.
  - Historic financial statements must be audited by a certified accountant.
  - Historic financial statements must be complete, including all notes to the financial statements.

Historic financial statements must correspond to accounting periods already completed and audited (no statements for partial periods shall be requested or accepted).

**Annexure-B4****AVERAGE ANNUAL TURNOVER**

Bidder's Legal Name: \_\_\_\_\_  
 JV Partner Legal Name: \_\_\_\_\_

Date: \_\_\_\_\_  
 ICB No.: \_\_\_\_\_  
 Page \_\_\_ of \_\_\_ pages

*[Each Bidder or member of a JV must fill in this form]*

<b>Annual Turnover Data for the Last 5 Years</b>			
<b>Year</b>	<b>Amount Currency</b>	<b>Exchange Rate</b>	<b>Pak Rs Equivalent</b>
<b>Average Annual Turnover</b>			

Average annual turnover calculated as total certified payments received for work in progress or completed, divided by the number of years specified.



**FINANCIAL RESOURCES**

Bidder's Legal Name: \_\_\_\_\_  
 JV Partner Legal Name: \_\_\_\_\_

Date: \_\_\_\_\_  
 ICB No.: \_\_\_\_\_  
 Page \_\_\_ of \_\_\_ pages

*[Specify proposed sources of financing, such as liquid assets, unencumbered real assets, lines of credit, and other financial means, net of current commitments, available to meet the total construction cash flow demands of the subject contract.]*

<b>Financial Resources</b>		
<b>No.</b>	<b>Source of financing</b>	<b>Amount [Pak Rs Equivalent]</b>
1		
2		
3		

**Annexure-B6****MANUFACTURER'S AUTHORIZATION**

Bidder's Legal Name: \_\_\_\_\_ Date: \_\_\_\_\_  
 ICB No.: \_\_\_\_\_

*[The Bidder shall require the Manufacturer to fill in this Form in accordance with the instructions indicated. This letter of authorization should be signed by a person with the proper authority to sign documents that are binding on the Manufacturer. The Bidder shall include it in its bid.]*

To: \_\_\_\_\_

**WHEREAS**

We \_\_\_\_\_, who are official manufacturers of \_\_\_\_\_, having factories at \_\_\_\_\_, do hereby authorize \_\_\_\_\_ to submit a bid the purpose of which is to provide the following goods, manufactured by us \_\_\_\_\_, and to subsequently negotiate and sign the Contract.

We hereby extend our full guarantee and warranty with respect to the goods offered by the above firm.

Signed: \_\_\_\_\_

Name: \_\_\_\_\_

Title: \_\_\_\_\_

Duly authorized to sign this Authorization on behalf of:

\_\_\_\_\_

Dated on \_\_\_\_\_ day of \_\_\_\_\_, \_\_\_\_\_

**KEY PERSONNEL**

Bidder's Legal Name: \_\_\_\_\_ Date: \_\_\_\_\_  
 ICB No.: \_\_\_\_\_

*[Bidders should provide the names of suitably qualified personnel to meet the requirements as specified. The data on their experience should be supplied using the Form Annexore-B8 below for each candidate.]*

<b>Key Personnel</b>	
<b>1.</b>	<b>Title of position*</b>
	<b>Name</b>
<b>2.</b>	<b>Title of position*</b>
	<b>Name</b>
<b>3.</b>	<b>Title of position*</b>
	<b>Name</b>
<b>4.</b>	<b>Title of position*</b>
<b>5.</b>	<b>Title of position*</b>
	<b>Name</b>

\*As listed in Annexure-B





**Annexure-B10**

**GENERAL EXPERIENCE**

Bidder's Legal Name: \_\_\_\_\_  
 JV Partner Legal Name: \_\_\_\_\_

Date: \_\_\_\_\_  
 ICB No.: \_\_\_\_\_  
 Page \_\_\_ of \_\_\_ pages

*[Each Bidder or member of a JV must fill in this form]*

<b>General Experience</b>				
<b>Starting Month Year</b>	<b>Ending Month Year</b>	<b>Years</b>	<b>Contract Identification and Name Name and Address of Employer Brief Description of the Works Executed by the Bidder</b>	<b>Role of Bidder</b>

*[List calendar year for years with contracts with at least nine (9) months activity per year starting with the earliest year.]*

## SPECIFIC EXPERIENCE

Bidder's Legal Name: \_\_\_\_\_  
 JV Partner Legal Name: \_\_\_\_\_

Date: \_\_\_\_\_  
 ICB No.: \_\_\_\_\_  
 Page \_\_\_ of \_\_\_ pages

[Fill up one (1) form per contract]

Contract of Similar Size and Nature		
Contract No . . .	Contract Identification	
Award Date	Completion Date	
Role in Contract	Contractor	Management Contractor Subcontractor
Total Contract Amount	Pak Rs	
If partner in a JV or subcontractor, specify participation of total contract amount	Percent of Total	Amount
Employer's Name Address  Telephone/Fax Number  E-mail		
Description of the similarity		
Amount		
Physical size		
Complexity		
Methods/Technology		
Physical Production Rate		

**Annexure-B12****CURRENT CONTRACT COMMITMENTS**

Bidder's Legal Name: \_\_\_\_\_ Date: \_\_\_\_\_  
 JV Partner Legal Name: \_\_\_\_\_ ICB No.: \_\_\_\_\_  
 Page \_\_\_ of \_\_\_ pages

*[Bidders and each partner to a JV should provide information on their current commitments on all contracts that have been awarded, or for which a letter of intent or acceptance has been received, or for contracts approaching completion, but for which an unqualified, full completion certificate has yet to be issued.]*

<b>Current Contract Commitments</b>					
<b>No.</b>	<b>Name of Contract</b>	<b>Employer's Contact Address, Tel, Fax</b>	<b>Value of Outstanding Work [Current Pak Rs Equivalent]</b>	<b>Estimated Completion Date</b>	<b>Average Monthly Invoicing Over Last Six Months [Rs/month]</b>
1					
2					
3					
4					
5					



**PENDING LITIGATION**

Bidder's Legal Name: \_\_\_\_\_  
 JV Partner Legal Name: \_\_\_\_\_

Date: \_\_\_\_\_  
 ICB No.: \_\_\_\_\_  
 Page \_\_\_ of \_\_\_ pages

*[Each Bidder or member of a JV must fill in this form]*

<b>Pending Litigation</b>			
<b>No pending litigation</b>			
<b>Pending litigation</b>			
<b>Year</b>	<b>Matter in Dispute</b>	<b>Value of Pending Claim in Pak Rs Equivalent</b>	<b>Value of Pending Claim as a Percentage of Net Worth</b>

## Annexure-C to Bidding Data

**DOMESTIC GOODS**  
**(Value added in Pakistan)**

Bidder's Legal Name: \_\_\_\_\_ Date: \_\_\_\_\_  
ICB No.: \_\_\_\_\_

*[Bidders claiming eligibility for domestic preference should fill in for supply items only, all columns hereunder and provide necessary documentation to substantiate their claim]*

Sr. No.	Description of Indigenous Goods	Unit	Qty	Total Price of Goods Ex-Factory (Pak Rs.)	Domestic value added in the manufacturing cost as percentage of Ex-Factory Price	Amount of value addition (Pak Rs.)
1	2	3	4	5	6	7
<b>Total in columns 5 &amp; 7</b>						
<b>Computations:</b>						
A. Total amount of Value Addition (from Col.7)						Rs _____
Total Ex-Factory Price of Indigenous Goods (from Col.5)						
C. Total DDP Price of imported supply items						Rs _____
D. Total Price of supply items [B+C]						Eqv.Rs _____
E. % of value addition = [(A/D)x100]						Eqv.Rs _____
F. Domestic Preference =(15,20 or 25)% of B						_____ %
						Rs _____

---

**LETTER OF BID  
AND  
APPENDICES TO BID**

## LETTER OF BID

Bid Reference No. \_\_\_\_\_

*Name of work:*

*Sub Work:*

*E/Cost = Rs: \_\_\_\_\_ Million*

To:

*Executive Engineer  
Swabi Irrigation Division-II Swabi*

Gentleman,

1. Having examined the Bidding Documents including Instructions to Bidders, Bidding Data, Conditions of Contract, Specifications, Drawings and Bill of Quantities and Addenda Nos. \_\_\_\_\_ for the execution of the above-named Works, we, the undersigned, offer to execute and complete such Works and remedy any defects therein in conformity with the Conditions of Contract. Specifications, Drawings, Bill of Quantities and Addenda for the sum of Rs. \_\_\_\_\_ (Rupees \_\_\_\_\_) or such other sum as may be ascertained in accordance with the said conditions.
2. We understand that all the Appendices attached hereto form part of this Bid.
3. As security for due performance of the undertakings and obligations of this Bid, we submit herewith a Bid Security/additional security in the amount of Rupees \_\_\_\_\_ (Rs. \_\_\_\_\_) drawn in your favour or made payable to you and valid for a period of \_\_\_\_\_ days beginning from the date Bids are opened.
4. We undertake, if our Bid is accepted, to commence the Works and to complete the whole of the Works comprised in the Contract within the time stated in Contract Data.
5. We agree to abide by this Bid for the period of \_\_\_\_\_ days from the date fixed for receiving the same and it shall remain binding upon us and may be accepted at any time before the expiration of that period.
6. Unless and until a formal Agreement is prepared and executed, this Bid, together with your written acceptance thereof, shall constitute a binding contract between us.
7. We undertake, if our Bid is accepted, to execute the Performance Security referred to in Sub Clause 4.2 of Conditions of Contract for the due performance of the Contract.
8. We understand that you are not bound to accept the lowest or any Bid you may receive.
9. We do hereby declare that the Bid is made without any collusion, comparison of figures or arrangement with any other bidder for the Works.
10. We confirm, if our Bid is accepted, that all partners of the joint venture shall be liable jointly and severally for the execution of the Contract and the composition or the constitution of the joint venture shall not be altered without the prior consent of the Employer. *[Please delete in case of Bid from a single firm].*

Dated this \_\_\_\_\_ day of \_\_\_\_\_ 20\_\_\_\_\_

Signature: \_\_\_\_\_

in the capacity of \_\_\_\_\_duly authorized to sign Bids for and on behalf of

\_\_\_\_\_  
*(Name of Bidder in Block Capitals)*  
*(Seal)*

Address: \_\_\_\_\_  
\_\_\_\_\_  
\_\_\_\_\_

Witness:

Signature: \_\_\_\_\_

Name: \_\_\_\_\_

Address. \_\_\_\_\_

\_\_\_\_\_  
Occupation \_\_\_\_\_

**A-1**  
**Appendix-A to Bid**

**SCHEDULE OF ADJUSTMENT DATA**

**Table I. Local Currency (LC) (NA)**

*[In the Table below, the Bidder shall (a) indicate amount of local currency payment, and the Employer shall (b) enter the source and base values of indices for the different elements of cost, and (c) derive weightings for local currency payment including nonadjustable fixed portion. The source of indices and weightings or coefficients is for use in the adjustment formula under Sub Clause-13.8.]*

Index code	Index description	Source of index	Base value and date	Bidder's related currency amount	Weighting
(i)	Non-adjustable	—	—	—	A: <b>0.35</b>
(ii)		—	—	—	B: _____
(iii)		—	—	—	C: _____
(iv)		—	—	—	D: _____
(v)		—	—	—	E: _____
(vi)		—	—	—	F: _____
(vii)	High Speed Diesel				G: _____
<b>Total</b>					<b>1.00</b>

**Notes:**

- 1) Indices, its source and base value are taken from Pakistan Institute of Cost and Contract (PICC), a subsidiary of PEC. The base cost indices or reference prices, each of which is applicable to the relevant tabulated cost element, shall be for the month falling on the day 28 days prior to the latest day for submission of bids. Current indices or reference prices for period “n” is applicable to the relevant tabulated cost element and shall be for the month falling on the day 49 days prior to the last day of the period (to which the particular Payment Certificate relates).
- 2) Any fluctuation in the indices or prices of materials other than those given above shall not be subject to adjustment of the Contract Price.
- 3) The Employer shall determine the weightings of non-adjustable portion considering only those cost elements having cost impact of five (5) percent or more specific to the project. The non-adjustable portion (0.35) indicated above is for example only and the actual shall be worked out by subtracting sum of all adjustable weightings from (1.00) one.  
*[Employers using this price adjustment provisions may add or delete any elements as deemed appropriate to the project.]*

**SCHEDULE OF ADJUSTMENT DATA**

**Table II. Foreign Currency (FC) (NA)**

*[In the Table below, the Bidder shall (a) indicate amount of foreign currency payment, (b) indicate the source and base values of indices for the different foreign currency elements of cost, (c) derive its proposed weightings foreign currency payment, except the non-adjustable portion which will be filled in by the Employer.*

*If the Bidder wishes to quote in more than one foreign currency (up to three currencies permitted) then this table should be repeated for each foreign currency.*

*In the case of very large and/or complex works contracts, it may be necessary to specify several families of price adjustment formulae corresponding to the different works involved.*

*The sources of indices and weightings or coefficients are for use in the adjustment formula under Sub Clause-13.8.]*

Index code	Index description	Source of index	Base value and date	Bidder's related source currency in type/amount	Equivalent in FC1	Bidder's proposed weighting
(i) (ii) (iii) (iv) (v)	Non-adjustable	—	—	—		A: _____ B: _____ C: _____ D: _____ E: _____
<b>Total</b>						<b>1.00</b>

**[Note:** *If the Bidder failed to provide information regarding Weightings, Base Value and Source of Index, then it is deemed that the Contractor has foregone his right to claim price adjustment in Foreign Currency.]*

**A-3**  
**Appendix-A to Bid**

**SCHEDULE OF ADJUSTMENT DATA**

**Table III. Foreign Currency Requirements (NA)**

*[With reference to Sub Clauses 14.3 and 13.8, the Bidder shall provide information below on the proportion of various currencies in which he requires payment to be made. The Bidders shall also indicate Factors (inputs) related to the requirement of respective currencies.]*

Sr.No	Currency (name)	Percentage payable in currency	Factors (inputs) to which the Requirements Refer
1.	<b>LC</b> (Pakistan Rupee Rs)		
2.	<b>FC1</b> (US \$ Dollar)		
3.	<b>FC2</b> (EUR € EURO)		
4.	<b>FC3</b>		
<b>TOTAL</b>		<b>100.00</b>	

*[\*The above Factors (Inputs) related to the requirement of respective currencies, are for guidance only, and shall be indicated specific to the project.]*



**SCHEDULE OF ADJUSTMENT DATA**

**Table IV. Summary of Payment Currencies (NA)**

*[In the Table below, the Bidder shall list the exchange rates used in the currency conversion.]*

Name of payment currency	a Amount of currency	b Rate of exchange (local currency per unit of foreign)	c Local currency equivalent $c = a \times b$	d Percentage of Total Bid Price (TBP) $\frac{100 \times c}{TBP}$
Local currency (Pakistan Rupee Rs)		1.00		
FC1 _____				
FC2 _____				
FC3 _____				
Total Bid Price				100.00
Provisional sums expressed in local currency	<i>[To be entered by the Employer]</i>		<i>[To be entered by the Employer]</i>	
<b>TOTAL BID PRICE</b> (including provisional sum)				

**B-1**  
**Appendix-B to Bid**

**BILL OF QUANTITIES**

**SPECIFIC WORKS DATA**

*[Proforma for specific Data to be prepared and incorporated by the Employer which will be filled in by the bidders]*

**D-1**  
**Appendix-D to Bid**

**WORK TO BE PERFORMED BY SUBCONTRACTORS (NA)**

The bidder will do the work with his own forces except the work listed below which he intends to sub-contract.

Sr. No.	Items of Work to be Sub-Contracted	Name and address of Sub-Contractor	Statement of similar works previously executed(attach evidence)

**Note:**

1. No change of Sub-Contractor shall be made by the bidder without prior approval of the Employer.
2. The truthfulness and accuracy of the statement as to the experience of Sub-Contractors is guaranteed by the bidder. The Employer's judgment shall be final as to the evaluation of the experience of Sub-Contractors submitted by the bidder.
3. Statement of similar works shall include description, location & value of work, year completed and name & address of the clients.

## **PROPOSED PROGRAMME OF WORKS**

Bidder shall provide a programme in a bar-chart/CPM/PERT form showing the sequence of work items by which he proposes to complete the work of the entire Contract. The programme should indicate the sequence of work items and the period of time during which he proposes to complete the Works including the activities like designing, schedule of submittal of drawings, ordering and procurement of materials, manufacturing, delivering, construction of civil works, erection, testing and commissioning of Works to be supplied under the Contract.

**F-1**  
**Appendix-F to Bid****DEVIATIONS FROM TECHNICAL PROVISIONS (NA)**

It is presumed that the bidder shall not take any deviation. However, if he intends to take deviations to the specified terms, those must be listed in the space provided below:

<b>Sr. No.</b>	<b>Clause No. / Section No.</b>	<b>Deviations/Clarifications</b>

*[Note: Attach additional sheets, if necessary]*

**DEVIATIONS FROM CONTRACTUAL CONDITIONS (NA)**

It is presumed that the bidder shall not take any deviation. However, if he intends to take deviations to the specified Contractual/Commercial Conditions, those must be listed in the space provided below:

<b>Sr. No.</b>	<b>Clause No. / Section No.</b>	<b>Deviations/Clarifications</b>

*[Note: Attach additional sheets, if necessary]*

**H-1**  
**Appendix-H to Bid****METHOD OF PERFORMING WORKS**

The bidder is required to submit a narrative outlining the method of performing the Works. The narrative should indicate in detail and include but not be limited to:

- The sequence and methods in which he proposes to carry out the Works, including the number of shifts per day and hours per shift, he expects to work.
- A list of all major items of constructional and erection plant, tools and vehicles proposed to be used in carrying out the Works at Site, including number of each kind, make, type, capacity of all equipment, working condition, which shall be deployed by him for Civil Work and Erection, Testing and Commissioning of the Works, in sufficient detail to demonstrate fully that the equipment will meet all the requirements of the Technical Provisions.
- The procedure for installation of equipment and transportation of equipment and materials to the site.
- Details regarding mobilisation in Pakistan, the type of facilities including personnel accommodation, office accommodation, provision for maintenance and for storage, communications, security and other services to be used.
- Methods of testing of the installed components according to specification and its evaluation to ascertain that the installed accessories are performing according to the specifications.



**ESTIMATED PROGRESS PAYMENTS (NA)**

Bidder's estimate of the value of work which would be executed by him during each of the periods stated below, based on his Programme of the Works and the Rates in the Bill of Quantities:

<b>Quarter</b>	<b>Foreign Currency Component</b>	<b>Local Currency Component</b>
Ist		
2 <sup>nd</sup>		
3 <sup>rd</sup>		
4 <sup>th</sup>		
5 <sup>th</sup>		
6 <sup>th</sup>		
7 <sup>th</sup>		
8 <sup>th</sup>		
9 <sup>th</sup>		
<b>Bid Price</b>		

**J-1**  
**Appendix-J to Bid****PROPOSED ORGANISATION**

Organisation chart indicating head office & field office personnel involved in management, supervision and engineering of the Works to be done under the Contract.

- Head Office:
  
  
  
  
  
  
  
  
  
  
- Site Office:
  
  
  
  
  
  
  
  
  
  
- Construction camp and housing facilities:  
*[The Bidder in accordance with Clause 6 of the Conditions of Contract shall provide description of his construction camp's facilities and staff housing requirements.  
The Bidder shall list or explain his plans for providing these facilities for the service of the Contract as follows:*
  1. *Site Preparation (clearing, land preparation, etc.).*
  2. *Provision of Services.*
    - a) *Power (expected power load, etc.).*
    - b) *Water (required amount and system proposed).*
    - c) *Sanitation (sewage disposal system, etc.)*
  3. *Construction of Facilities*
    - a) *Contractor's Office. Workshop and Work Areas (areas required and proposed layout, type of construction of buildings, etc.).*
    - b) *Warehouses and Storage Areas (area required, type of construction and layout).*
    - c) *Housing and Staff Facilities (Plans for housing for proposed staff, layout, type of construction, etc.).*
  4. *Construction Equipment Assembly and Preparation (detailed plans for carrying out this activity).*
  5. *Other Items Proposed (Security services, etc.)]*

**INTEGRITY PACT**  
**DECLARATION OF FEES, COMMISSION AND BROKERAGE ETC.**  
**PAYABLE BY THE SUPPLIERS OF GOODS, SERVICES & WORKS IN**  
**CONTRACTS WORTH RS. 10.00 MILLION OR MORE**

Contract No. \_\_\_\_\_ Dated \_\_\_\_\_  
Contract Value: \_\_\_\_\_  
Contract Title: \_\_\_\_\_

..... [name of Supplier] hereby declares that it has not obtained or induced the procurement of any contract, right, interest, privilege or other obligation or benefit from Government of Pakistan (GoP) or any administrative subdivision or agency thereof or any other entity owned or controlled by GoP through any corrupt business practice.

Without limiting the generality of the foregoing, [name of Supplier] represents and warrants that it has fully declared the brokerage, commission, fees etc. paid or payable to anyone and not given or agreed to give and shall not give or agree to give to anyone within or outside Pakistan either directly or indirectly through any natural or juridical person, including its affiliate, agent, associate, broker, consultant, director, promoter, shareholder, sponsor or subsidiary, any commission, gratification, bribe, finder's fee or kickback, whether described as consultation fee or otherwise, with the object of obtaining or inducing the procurement of a contract, right, interest, privilege or other obligation or benefit in whatsoever form from GoP, except that which has been expressly declared pursuant hereto.

[name of Supplier] certifies that it has made and will make full disclosure of all agreements and arrangements with all persons in respect of or related to the transaction with GoP and has not taken any action or will not take any action to circumvent the above declaration, representation or warranty.

[name of Supplier] accepts full responsibility and strict liability for making any false declaration, not making full disclosure, misrepresenting facts or taking any action likely to defeat the purpose of this declaration, representation and warranty. It agrees that any contract, right, interest, privilege or other obligation or benefit obtained or procured as aforesaid shall, without prejudice to any other rights and remedies available to GoP under any law, contract or other instrument, be voidable at the option of GoP.

Notwithstanding any rights and remedies exercised by GoP in this regard, [name of Supplier] agrees to indemnify GoP for any loss or damage incurred by it on account of its corrupt business practices and further pay compensation to GoP in an amount equivalent to ten times the sum of any commission, gratification, bribe, finder's fee or kickback given by [name of Supplier] as aforesaid for the purpose of obtaining or inducing the procurement of any contract, right, interest, privilege or other obligation or benefit in whatsoever form from GoP.

Name of Buyer:/ Employer.....  
.....

Name of Seller/Supplier: /Bidder

Signature: .....  
[Seal]

Signature: .....  
[Seal]



# **STANDARD FORMS**

## FORM OF BID SECURITY

*(Bank / Insurance Company Guarantee\*)*

Security Executed on \_\_\_\_\_  
(Date)

Name of Surety (Bank with Address:) \_\_\_\_\_  
(Scheduled Bank)

Name of Principal (Bidder) with Address \_\_\_\_\_

Penal Sum of Security Rupees. \_\_\_\_\_ (Rs. \_\_\_\_\_)

Bid Reference No. \_\_\_\_\_

KNOW ALL MEN BY THESE PRESENTS, that in pursuance of the terms of the Bid and at the request of the said Principal (Bidder) we, the Surety above named, are held and firmly bound unto \_\_\_\_\_

(hereinafter called the 'Employer') in the sum stated above for the payment of which sum well and truly to be made, we bind ourselves, our heirs, executors, administrators and successors, jointly and severally, firmly by these presents.

THE CONDITION OF THIS OBLIGATION IS SUCH, that whereas the Bidder has submitted the accompanying Bid dated \_\_\_\_\_ for Bid No. \_\_\_\_\_ for \_\_\_\_\_ *(Particulars of Bid)* to the said Employer; and

WHEREAS, the Employer has required as a condition for considering said Bid that the Bidder furnishes a Bid Security in the above said sum to the Employer, conditioned as under:

- (1) that the Bid Security shall remain valid for a period 28 days beyond the period of validity of the Bid;
- (2) that in the event of;
  - (a) the Principal withdraws his Bid during the period of validity of Bid, or
- (b) the Principal does not accept the correction of his Bid Price, pursuant to Sub-Clause 26.2 of Instructions to Bidders, or
  - (c) failure of the successful bidder to
- (i) furnish the required Performance Security, in accordance with Clause 36 of Instructions to Bidders, or
- (ii) sign the proposed Contract Agreement, in accordance with Clause 37 of Instructions to Bidders, then the entire sum be paid immediately to the said Employer as liquidated damages and not as penalty for the successful bidder's failure to perform

NOW THEREFORE, if the successful Bidder shall, within the period specified therefore, on the prescribed form presented to him for signature enter into a formal Contract with the said Employer in accordance with his Bid as accepted and furnish within twenty eight (28) days of his being requested to do so, a Performance Security with good and sufficient surety, as may be required, upon the form prescribed by the said Employer for the faithful performance and proper fulfilment of the said Contract or in the event of non-withdrawal of the said Bid within the time specified for its validity then this obligation shall be void and of no effect, but otherwise to remain in full force and effect.

PROVIDED THAT the Surety shall forthwith pay the Employer the said sum upon first written demand of the Employer (without cavil or argument) and without requiring the Employer to prove or to show grounds or reasons for such demand, notice of which shall be sent by the Employer by registered post duly addressed to the Surety at its address given above.

PROVIDED ALSO THAT the Employer shall be the sole and final judge for deciding whether the Principal (Bidder) has duly performed his obligations to sign the Contract Agreement and to furnish the requisite Performance Security within the time stated above, or has defaulted in fulfilling said requirements and the Surety shall pay without objection the said sum upon demand

Specifications

---

from the Employer forthwith and without any reference to the Principal (Bidder) or any other person.

IN WITNESS WHEREOF, the above bounden Surety has executed the instrument under its seal on the date indicated above, the name and seal of the Surety being hereto affixed and these presents duly signed by its undersigned representative pursuant to authority of its governing body.

SURETY (*Bank*)

WITNESS:

Signature \_\_\_\_\_

1. \_\_\_\_\_  
\_\_\_\_\_  
Corporate Secretary (Seal)

Name \_\_\_\_\_  
Title \_\_\_\_\_  
Corporate Guarantor (Seal)

2. \_\_\_\_\_  
\_\_\_\_\_  
Name, Title & Address

*\*Delete whichever is not applicable*

## FORM OF PERFORMANCE SECURITY

*(Bank)*

Guarantee No. \_\_\_\_\_

Executed on \_\_\_\_\_

Expiry date \_\_\_\_\_

[Letter by the Guarantor to the Employer]

Name of Guarantor (Bank/Insurance Company) with address: \_\_\_\_\_

*(Scheduled Bank / Insurance Company Rating-AA in Pakistan\*)*

Name of Principal (Contractor) with address: \_\_\_\_\_

Penal Sum of Security *(express in words and figures)* \_\_\_\_\_

Letter of Acceptance No. \_\_\_\_\_ Dated \_\_\_\_\_

KNOW ALL MEN BY THESE PRESENTS, that in pursuance of the terms of the Bidding Documents and above said Letter of Acceptance (hereinafter called the Documents) and at the request of the said Principal we, the Guarantor above named, are held and firmly bound unto the

\_\_\_\_\_ (hereinafter called the Employer) in the penal sum of the amount stated above for the payment of which sum well and truly to be made to the said Employer, we bind ourselves, our heirs, executors, administrators and successors, jointly and severally, firmly by these presents.

THE CONDITION OF THIS OBLIGATION IS SUCH, that whereas the Principal has accepted the Employer's above said Letter of Acceptance for \_\_\_\_\_

\_\_\_\_\_ *(Name of Contract)* for the \_\_\_\_\_

\_\_\_\_\_ *(Name of Project)*.

NOW THEREFORE, if the Principal (Contractor) shall well and truly perform and fulfill all the undertakings, covenants, terms and conditions of the said Documents during the original terms of the said Documents and any extensions thereof that may be granted by the Employer, with or without notice to the Guarantor, which notice is, hereby, waived and shall also well and truly perform and fulfill all the undertakings, covenants terms and conditions of the Contract and of any and all modifications of said Documents that may hereafter be made, notice of which modifications to the Guarantor being hereby waived, then, this obligation to be void; otherwise to remain in full force and virtue till all requirements of Clause 11, Defects Liability, of Conditions of Contract are fulfilled.

Our total liability under this Guarantee is limited to the sum stated above and it is a condition of any liability attaching to us under this Guarantee that the claim for payment in writing shall be received by us within the validity period of this Guarantee, failing which we shall be discharged of our liability, if any, under this Guarantee.

We, \_\_\_\_\_ (the Guarantor), waiving all objections and defences under the Contract, do hereby irrevocably and independently guarantee to pay to the Employer without delay upon the Employer's first written demand without cavil or arguments and without requiring the Employer to prove or to show grounds or reasons for such demand any sum or sums up to the amount stated above, against the Employer's written declaration that the Principal has refused or failed to perform the obligations under the Contract which payment will be effected by the Guarantor to Employer's designated Bank & Account Number.

PROVIDED ALSO THAT the Employer shall be the sole and final judge for deciding whether the Principal (Contractor) has duly performed his obligations under the Contract or has defaulted in fulfilling said obligations and the Guarantor shall pay without objection any sum or sums up to the amount stated above upon first written demand from the Employer forthwith and without any reference to the Principal or any other person.

IN WITNESS WHEREOF, the above-bounden Guarantor has executed this Instrument under its seal on the date indicated above, the name and corporate seal of the Guarantor being hereto affixed and



**Specifications**

---

these presents duly signed by its undersigned representative, pursuant to authority of its governing body.

**Guarantor (Bank)**

WITNESS:

Signature \_\_\_\_\_

1. \_\_\_\_\_  
\_\_\_\_\_  
Corporate Secretary (Seal)

Name \_\_\_\_\_  
Title \_\_\_\_\_  
Corporate Guarantor (Seal)

2. \_\_\_\_\_  
\_\_\_\_\_  
Name, Title & Address

## FORM OF CONTRACT AGREEMENT

THIS CONTRACT AGREEMENT (hereinafter called the "Agreement") made on the \_\_\_\_\_ day of \_\_\_\_\_ (month) 20\_\_\_\_ between \_\_\_\_\_ (hereafter called the "Employer") of the one part and \_\_\_\_\_ (hereafter called the "Contractor") of the other part.

WHEREAS the Employer is desirous that certain Works, viz \_\_\_\_\_ should be executed by the Contractor and has accepted a Bid by the Contractor for the execution and completion of such Works and the remedying of any defects therein.

NOW this Agreement witnessed as follows:

1. In this Agreement words and expressions shall have the same meanings as are respectively assigned to them in the Conditions of Contract hereinafter referred to.
2. The following documents after incorporating addenda, if any, except those parts relating to Instructions to Bidders shall be deemed to form and be read and construed as part of this Agreement:
  - a) The Letter of Acceptance;
  - b) Letter of Bid;
  - c) The Particular Conditions – Part A Contract Data;
  - d) The Particular Conditions – Part B Specific Provisions;
  - e) The General Conditions;
  - f) The Specifications - Special Provisions;
  - g) The Specifications - Technical Provisions;
  - h) The Drawings;
  - i) The Completed Appendices to Bid including Priced BoQ; and
  - j) any other Documents forming part of the Contract.

The addenda, if any, (Excluding part relating to Instructions to Bidders alongwith Bidding Data) shall be deemed to have been incorporated at the appropriate places in the documents forming the Contract".

3. In consideration of the payments to be made by the Employer to the Contractor as hereinafter mentioned, the Contractor hereby covenants with the Employer to execute and complete the Works and remedy defects therein in conformity and in all respects with the provisions of the Contract.
4. The Employer hereby covenants to pay the Contractor, in consideration of the execution and completion of the Works as per provisions of the Contract, the Contract Price or such other sum as may become payable under the provisions of the Contract at the times and in the manner prescribed by the Contract.

IN WITNESS WHEREOF the parties hereto have caused this Agreement to be executed on the day, month and year first before written in accordance with their respective laws.

\_\_\_\_\_  
Signature of the Contactor

\_\_\_\_\_  
Signature of Employer

\_\_\_\_\_  
(Seal)

\_\_\_\_\_  
(Seal)

Signed, Sealed and Delivered in the presence of:

\_\_\_\_\_  
Witness

\_\_\_\_\_  
Witness

\_\_\_\_\_  
(Name, Title and Address)

\_\_\_\_\_  
(Name, Title and Address)

**FORM OF MOBILIZATION ADVANCE GUARANTEE (NA)**

Guarantee No. \_\_\_\_\_ Date \_\_\_\_\_

WHEREAS \_\_\_\_\_ (hereinafter called the 'Employer')

has entered into a Contract for \_\_\_\_\_

(Particulars of Contract)

with \_\_\_\_\_ (hereinafter called the "Contractor").

AND WHEREAS, the Employer has agreed to advance to the Contractor, at the Contractor's request, an amount of Rupees \_\_\_\_\_ (Rs \_\_\_\_\_ ) which amount shall be advanced to the Contractor as per provisions of the Contract.

AND WHEREAS, the Employer has asked the Contractor to furnish Guarantee to secure the mobilization advance for the performance of his obligations under the said Contract.

AND WHEREAS, \_\_\_\_\_

(Scheduled Bank in Pakistan)

(hereinafter called the "Guarantor") at the request of the Contractor and in consideration of the Employer agreeing to make the above advance to the Contractor, has agreed to furnish the said Guarantee.

NOW, THEREFORE, the Guarantor hereby guarantees that the Contractor shall use the advance for the purpose of above mentioned Contract and if he fails and commits default in fulfilment of any of his obligations for which the advance payment is made, the Guarantor shall be liable to the Employer for payment not exceeding the aforementioned amount.

Notice in writing of any default, of which the Employer shall be the sole and final judge, on the part of the Contractor, shall be given by the Employer to the Guarantor, and on such first written demand, payment shall be made by the Guarantor of all sums then due under this Guarantee without any reference to the Contractor and without any objection.

This Guarantee shall remain in force until the advance is fully adjusted against payments from the Interim Payment Certificates of the Contractor or until \_\_\_\_\_ whichever is earlier. (Date)

The Guarantor's liability under this Guarantee shall not in any case exceed the sum of Rupees \_\_\_\_\_ (Rs \_\_\_\_\_).

This Guarantee shall remain valid up to the aforesaid date and shall be null and void after the aforesaid date or earlier if the advance made to the Contractor is fully adjusted against payments from Interim Payment Certificates of the Contractor provided that the Guarantor agrees that the aforesaid period of validity shall be deemed to be extended if on the above mentioned date the advance payment is not fully adjusted.

Guarantor

(Scheduled Bank/ Insurance Company\*)

WITNESS:

Signature \_\_\_\_\_

1. \_\_\_\_\_

Name \_\_\_\_\_

Corporate Secretary (Seal)

Title \_\_\_\_\_

Corporate Guarantor (Seal)

2. \_\_\_\_\_

\_\_\_\_\_  
Name, Title & Address

*\*Delete whichever is not applicable*

# **CONDITIONS OF CONTRACT**

## **CONDITIONS OF CONTRACT**

The Conditions of Contract comprise General Conditions (GC) and Particular Conditions (PC):

### **General Conditions**

The General Conditions that follow are the FIDIC Conditions of Contract for Plant and Design – Build for Electrical and Mechanical Plant, and for Building and Engineering Works Designed by the Contractor, also known as the Plant and Design-Build Contract, First Edition-1999, prepared and copyrighted by the International Federation of Consulting Engineers (Fédération Internationale des Ingénieurs-Conseils, or FIDIC). Provision is also made for the Employer (or his Engineer) to design elements of the Works.

The standard text of the General Conditions chosen must be retained intact to facilitate its reading and interpretation by bidders and its review by the Employer. Any amendments and additions to the General Conditions, specific to the contract in hand, should be introduced in the Particular Conditions.

The FIDIC Conditions of Contract are copyrighted and may not be copied, faxed, or reproduced. Copies of the FIDIC Conditions of Contract, for Plant and Design – Build, First Edition-1999 can be obtained from:

FIDIC Secretariat

P.O. Box 86

1000 Lausanne 12

Switzerland

e-mail: [fidic.pub@fidic.org](mailto:fidic.pub@fidic.org) – [FIDIC.org/bookshop](http://FIDIC.org/bookshop)

### Particular Conditions

The Particular Conditions (PC) complement the General Conditions (GC) to specify dates, contractual requirements, and special circumstances related to the Works. The PC consists of two parts, Part A, Contract Data and Part B, Specific Provisions:

#### Part A - Contract Data

Conditions	Ref. GC	Data
Employer's name and address	1.1.2.2 & 1.3	Executive Engineer Swabi Irrigation Division-II Swabi Office of Executive Engineer Swabi Irrigation Division-II Swabi Telephone/Fax No 0938-920031, Email: <a href="mailto:xenwswabi@yahoo.com">xenwswabi@yahoo.com</a>
Engineer's name and address	1.1.2.4 & 1.3	Executive Engineer Swabi Irrigation Division-II Swabi Office of Executive Engineer Swabi Irrigation Division-II Swabi Telephone/Fax No 0938-920031, Email: <a href="mailto:xenwswabi@yahoo.com">xenwswabi@yahoo.com</a>
Time for Completion	1.1.3.3	days
Defects Period	1.1.3.7	06 months [As required by the Employer]
Sections	1.1.5.6	[If sections are used, refer to table Summary of Sections below]
Governing Law	1.4	Islamic Republic of Pakistan
Ruling language	1.4	English
Language for communications	1.4	English
Time for access to the Site	2.1	No later than the Commencement Day, except for the following parts (if applicable, with detailed description of parts concerned: 03 days after Commencement Date.
Engineer's Duties and Authority	3.1(j)(ii)	Variations resulting in an increase of the Accepted Contract Amount in excess of 2% shall require approval of the Employer.
Performance Security	4.2	10% of the Accepted Contract Amount
Normal working hours	6.5	8 Hours
Waranty		As per relevant specification
Delay damages for the Works	8.7 & 14.15(b)	Rs. 0.05% of the amount stated in the Letter of Acceptance for each day of delay in completion Works
Maximum amount of delay damages	8.7	@ 0.05% of bid cost per day

Conditions	Ref. GC	Data
Bonus for early completion	8.13	Rs. Nil for each day of early completion of Works
Max. amount of Bonus	8.13	NA
Adjustment on Provisional Sums	13.5.(b)(ii)	NA
Advance payment/Repayment of Advance	14.2, 8.1(d)	NA
Percentage of Retention	14.3	8% of the amount of Interim Payment Certificate
Limit of Retention Money	14.3	8% of Contract Price

<b>Conditions</b>	<b>Ref. GC</b>	<b>Data</b>
<b>Plant and Materials</b>	14.5(b)(i)	<i>If Sub-Clause 14.5 applies: Plant and Materials for payment Free on Board _NA</i>
	14.5(c)(i)	<i>Plant and Materials for payment when delivered to the Site ___NA_____.</i>
<b>Minimum Amount of Interim Payment Certificates</b>	14.6	<i>1.00 Million</i>
<b>Maximum total liability of the Contractor to the Employer</b>	17.6	<i>The Contract Price</i>
<b>Periods for submission of insurance: evidence of insurance. relevant policies</b>	18.1	<i>NA</i>
<b>Maximum amount of deductibles for insurance of the Employer's risks</b>	18.2(d)	<i>NA</i>
<b>Minimum amount of third party insurance</b>	18.3	<i>NA</i>
<b>Appointment of the Adjudicator</b>	20.2	<i>14 days after the Commencement date</i>
<b>Appointment (if not agreed) to be made by</b>	20.3	<i>Pakistan Engineering Council (PEC)</i>
<b>Rules of arbitration</b>	20.6	<i>PEC Rules of Conciliation and Arbitration Place of Arbitraation is District Swabi</i>

**Summary of Sections of the Works**

<b>Section Name/Description (Sub-Clause 1.1.5.6)</b>	<b>Time for Completion (Sub-Clause 1.1.3.3)</b>	<b>Damages for Delay (Sub-Clause 8.7)</b>
A		
B		
C		

<b>Section Name/Description (Sub-Clause 1.1.5.6)</b>	<b>Time for Completion (Sub-Clause 1.1.3.3)</b>	<b>Bonus for Early Completion (Sub-Clause 8.13)</b>
A		
B	NA	
C		



## **Particular Conditions**

### **Part B - Specific Provisions**

#### **The Contract**

Sub Clause 1.1.1.6

The word "**Schedules**" is replaced with "**Appendices to Bid**

Sub-Clause 1.1.1.10

Replaced the text with "**Contract Data**" means the pages completed by the Employer entitled contract data which constitute Part A of the Particular Conditions, and Appendices to Bid including Bill of Quantities, Contract Data and Specific Provision comprised in the Contract"

#### **1.1.2 Parties and Persons**

Sub Clause 1.1.2.9: The text may be replaced as;

"Adjudicator" means the person appointed under Sub-Clause 20.2 [Appointment of the Adjudicator] or Sub-Clause 20.3 [Failure to Agree on the Appointment or Replacement of Adjudicator]

#### **Interpretation**

Add following sub-paragraph (e):

"The word 'tender' is synonymous with 'bid' and the words 'tender documents' are synonymous with 'bidding documents'"

#### **Priority of Documents**

The documents listed at (a) through (i) of this Sub-Clause are deleted and substituted with the following:

- (a) The Contract Agreement;
- (b) The Letter of Acceptance;
- (c) Letter of Bid;
- (d) The Particular Conditions – Part A Contract Data;
- (e) The Particular Conditions – Part B Specific Provisions;
- (f) The General Conditions;
- (g) The Specifications - Special Provisions;
- (h) The Specifications - Technical Provisions;
- (i) The Drawings;
- (j) The Completed Appendices to Bid including Priced BOQ; and
- (k) any other Documents forming part of the Contract.

*[The addenda, if any, (Excluding part relating to Instruction to Bidders along with Bid Data) shall be deemed to have been incorporated at the appropriate places in the documents forming the Contract.]*

auses are added after Sub-Clause 1.14:

#### **Shop Drawings**

The Contractor shall submit to the Engineer for review 3 copies of all shop and erection drawings applicable to this Contract as per provision of relevant Sub-Clause of the Contract.

Review and approval by the Engineer shall not be construed as a complete check but will indicate only that the general method of construction and detailing is satisfactory and the Engineer's review or approval shall not relieve the Contractor of any of his responsibilities under the Contract.

#### **As-Built Drawings**

At the completion of the Works under the Contract, the Contractor shall furnish to the Engineer 6 copies and one reproducible of all drawings amended to conform to the Works as built. The price of such Drawings shall be deemed to be included in the Contract Price.

#### **Employer's Claims**

In the second last line of last paragraph, after words 'Payment Certificate', the following is added:

"or from the encashment of Performance Security or from other assets of the Contractor"

<b>Engineer's Duties and Authority</b>	<p>Paragraph No.5 is replaced as under:</p> <p>Except before taking any of the following actions specified in the General Conditions, the Engineer shall obtain the specific approval of the Employer in writing:</p> <ol style="list-style-type: none"> <li>a) Any action under Sub-Clause 4.2 "Performance Security" and Clause 18 "Insurance".</li> <li>b) Consenting to the sub-letting of any part of the Works under Sub-Clause 4.4 "Subcontractors".</li> <li>c) certifying an additional Cost arising on account of unforeseeable physical conditions under Sub-Clause 4.12;</li> <li>d) Any action under Sub-Clause 8.7 "Delay Damages" or Payment of Bonus for Early Completion of Works (PC Sub-Clause 8.13).</li> <li>e) determining an extension of Time for Completion under Sub-Clause 8.4</li> <li>f) Any action under Sub-Clause 8.8 "Suspension of Work", Sub-Clause 8.9 "Consequences of Suspension", Sub-Clause 8.10 "Payment for Plant and Materials in Event of Suspension" and Sub-Clause 8.11 "Prolonged Suspension".</li> <li>g) Issuance of "Taking Over Certificate" under Sub-Clause 10.1 "Taking Over of the Works and Sections".</li> <li>h) Issuing the "Performance Certificate" under Sub-Clause 11.9.</li> <li>i) Agreeing or determining cost under Sub-Clause 12.4.</li> <li>j) Issuing variation instruction under Sub-Clause 13. Except: <ol style="list-style-type: none"> <li>(i) in an emergency situation, as reasonably determined by the Engineer or</li> <li>(ii) if such variation instruction would increase the Contract Price by less than specified in Contract Data.</li> </ol> </li> <li>k) Certifying release of retention money under Sub-Clause 14.9.</li> <li>l) Issuing Final Payment Certificate under Sub-Clause 14.13.</li> <li>m) Any action in the event of Force Majeure under Sub-Clause 19.2</li> <li>n) Agreeing or determining EOT and or additional cost under Sub-Clause 20.1</li> </ol>
<b>Delegation by the Engineer</b>	<p>The following text is added at the end of this Sub-Clause:</p> <p>The Employer shall ensure that the Engineer is a "Registered Professional Engineer", defined in the Pakistan Engineering Council Act 1975 (V of 1976).</p>
<b>Performance Security</b>	<p>At the end of 2<sup>nd</sup> paragraph the following is added:</p> <p>"An entity and from within a country (or other jurisdiction)" is meant for "a Scheduled Bank of Pakistan or any other bank located outside Pakistan duly counter guaranteed by a Scheduled Bank of Pakistan.</p> <p>In case of Joint Venture, the Performance Security shall be in the name of the Joint Venture."</p>
<b>Safety Procedures</b>	<p>The following text is added at the end of this Sub-Clause:</p> <p>In the event of work being carried out outside the normal working hours and in the event of work being carried out at night, the Contractor shall at his own cost, provide and maintain such good and sufficient light as will enable the work to proceed satisfactorily and without danger. The approaches to the Site and the Works where the night work is being carried out shall be sufficiently lighted. All arrangement adopted for such lighting shall be to the satisfaction of the Engineer.</p>
<b>Transport of Goods</b>	<p>The following is added at the end of sub paragraph (a):</p> <p>"The Contractor shall duly consider the nature, volume and weight of all Plant and Goods for the safe inland transportation up to the Site.</p>

After consultation with the Engineer, the Contractor shall, at its own risk and cost, use the most appropriate route for transporting the Plant and Goods without causing the impediments to the public transport and without causing any delay to the approved programme of the Works.”

The text of sub paragraph (b) is amended to read as under:

“The Contractor shall be responsible for proper packing, marking of packages in accordance with recognized international practices, shipping through vessels registered in any eligible source country or through conference line vessels, clearing from custom authorities, loading, inland transporting, receiving, unloading, storing and protecting of Plant, Goods and all other things required for the Works; and”

The following new paragraph is added at the end:

"The Contractor shall request the Engineer's permission for delivery of Plant or any item of Goods to the Site. No Plant or any item of Goods shall be delivered without this permission, which permission shall not relieve the Contractor from any of its obligations under the Contract."

**Contractor's  
Equipment**

The following text is added at the end of this Sub-Clause:

With a view to securing, in the event of termination under Clause 15, the continued availability, for the purpose of executing the Works, of any hired Contractor's Equipment, the Contractor shall not bring on to the Site any hired Contractor's Equipment unless there is an agreement for hire thereof (which agreement shall be deemed not to include an agreement for hire purchase) which contains a provision that the owner thereof will, on request in writing made by the Employer within 7 days after the date on which any termination has become effective, and on the Employer undertaking to pay all hire charges in respect thereof from such date, hire such Contractor's Equipment to the Employer on the same terms in all respect as the same was hired to the Contractor and that the Employer shall be entitled to permit the use thereof by any other Contractor employed by him for the purpose of execution and remedying any defects therein under Clause 15.

The Contractor shall, upon request by the Engineer at any time in relation to any item of hired Contractor's Equipment, forthwith notify the Engineer in writing the name and address of the Owner of the equipment and shall certify that the agreement for the hire thereof contains a provision in accordance with the requirement set forth above

**Engagement of Staff  
and Labour**

The following new paragraph is added at the end:

“The Contractor shall be required, to the extent practicable and reasonable, to employ maximum technical and non-technical staff with appropriate qualifications and experience, from the country, where the Site is located. However, the Contractor shall, in any case be obliged to prefer to employ unskilled labour from the towns/villages effected by the Works. “

**Contractor's  
Superintendence**

The following text is added at the end of this Sub-Clause:

The Contractor's authorized representative and his other professional engineers working at site shall possess registration with the Pakistan Engineering Council.

The Contractor's authorized representative at Site shall be authorized to exercise adequate administrative and financial powers on behalf of

the Contractor so as to achieve completion of the Works as per the Contract.

The following Sub-Clauses are added at the end of Sub-Clause 6.11:

<b>Foreign Personnel</b>	<p>The Contractor may bring in to the Country any foreign personnel who are necessary for the execution of the Works to the extent allowed by the applicable Laws. The Contractor shall ensure that these personnel are provided with the required residence visas and work permits. The Employer will, if requested by the Contractor, use his best endeavours in a timely and expeditious manner to assist the Contractor in obtaining any local, state, national, or government permission required for bringing in the Contractor's personnel.</p> <p>The Contractor shall be responsible for the return of these personnel to the place where they were recruited or to their domicile. In the event of the death in the Country of any of these personnel or members of their families, the Contractor shall similarly be responsible for making the appropriate arrangements for their return or burial.</p>
<b>Supply of Foodstuffs</b>	<p>The Contractor shall arrange for the provision of a sufficient supply of suitable food as may be stated in the Specification at reasonable prices for the Contractor's Personnel for the purposes of or in connection with the Contract.</p>
<b>Supply of Water</b>	<p>The Contractor shall, having regard to local conditions, provide on the Site an adequate supply of drinking and other water for the use of the Contractor's Personnel.</p>
<b>Measures against Insect and Pest Nuisance</b>	<p>The Contractor shall at all times take the necessary precautions to protect the Contractor's Personnel employed on the Site from insect and pest nuisance, and to reduce the danger to their health. The Contractor shall comply with all the regulations of the local health authorities, including use of appropriate insecticide.</p>
<b>Alcoholic Liquor or Drugs</b>	<p>The Contractor shall not, otherwise than in accordance with the Laws of the Country, import, sell, give, barter or otherwise dispose of any alcoholic liquor or drugs, or permit or allow importation, sale, gift, barter or disposal thereto by Contractor's Personnel.</p>
<b>Arms and Ammunition</b>	<p>The Contractor shall not give, barter, or otherwise dispose of, to any person, any arms or ammunition of any kind, or allow Contractor's Personnel to do so.</p>
<b>Festivals and Religious Customs</b>	<p>The Contractor shall respect the Country's recognized festivals, days of rest and religious or other customs.</p>
<b>Funeral Arrangements</b>	<p>The Contractor shall be responsible, to the extent required by local regulations, for making any funeral arrangements for any of his local employees who may die while engaged upon the Works.</p>
<b>Forced Labour</b>	<p>The Contractor shall not employ forced labour, which consists of any work or service, not voluntarily performed, that is exacted from an individual under threat of force or penalty, and includes any kind of involuntary or compulsory labour, such as indentured labour, bonded labour or similar labour-contracting arrangements.</p>
<b>Child Labour</b>	<p>The Contractor shall not employ children in a manner that is economically exploitative, or is likely to be hazardous, or to interfere with, the child's education, or to be harmful to the child's health or physical, mental, spiritual, moral, or social</p>

**Employment Records of Workers**

development. Where the relevant labour laws of the Country have provisions for employment of minors, the Contractor shall follow those laws applicable to the Contractor. Children below the age of 18 years shall not be employed in dangerous work.

The Contractor shall keep complete and accurate records of the employment of labour at the Site. The records shall include the names, ages, genders, hours worked and wages paid to all workers. These records shall be summarised on a monthly basis and submitted to the Engineer. These records shall be included in the details to be submitted by the Contractor under Sub-Clause 6.10 [Records of Contractor's Personnel and Equipment].

**Workers' Organisations**

In countries where the relevant labour laws recognise workers' rights to form and to join workers' organisations of their choosing without interference and to bargain collectively, the Contractor shall comply with such laws. Where the relevant labour laws substantially restrict workers' organisations, the Contractor shall enable alternative means for the Contractor's Personnel to express their grievances and protect their rights regarding working conditions and terms of employment. In either case described above, and where the relevant labour laws are silent, the Contractor shall not discourage the Contractor's Personnel from forming or joining workers' organisations of their choosing or from bargaining collectively, and shall not discriminate or retaliate against the Contractor's Personnel who participate, or seek to participate, in such organisations and bargain collectively. The Contractor shall engage with such workers' representatives. Workers' organisations are expected to fairly represent the workers in the workforce.

**Non-Discrimination and Equal Opportunity**

The Contractor shall not make employment decisions on the basis of personal characteristics unrelated to inherent job requirements. The Contractor shall base the employment relationship on the principle of equal opportunity and fair treatment, and shall not discriminate with respect to aspects of the employment relationship, including recruitment and hiring, compensation (including wages and benefits), working conditions and terms of employment, access to training, promotion, termination of employment or retirement, and discipline. In countries where the relevant labour laws provide for non-discrimination in employment, the Contractor shall comply with such laws. When the relevant labour laws are silent on nondiscrimination in employment, the Contractor shall meet this Sub-Clause's requirements. Special measures of protection or assistance to remedy past discrimination or selection for a particular job based on the inherent requirements of the job shall not be deemed discrimination.

**Epidemics**

In the event of any out-break of illness of epidemic /pandemic nature, the Contractor shall comply with and carry out such regulations, orders and requirements as may be made by the Government or the local medical or sanitary authorities for the purpose of overcoming the same.

**Compliance by Sub-Contractor**

The Contractor shall be responsible for compliance by his Subcontractors of the provisions of all the relevant provisions of Clause 6 – Staff and Labour.

The following Sub-Clause is added after Sub Clause 7.8:

**Use of Pakistani Materials and Services** The Contractor shall, so far as may be consistent with the Contract, make the maximum use of materials, supplies, plant and equipment indigenous to or produced or fabricated in Pakistan and services, available in Pakistan provided such materials, supplies, plant, equipment and services shall be of required standard.

The following Sub-Clause is added after Sub-Clause 8.12:

**Bonus for Early Completion of Works The Contract Price**

The following is added at the end:

The Engineer shall agree or determine the value of those parts of the Works which are to be measured, in accordance with Sub-Clause 3.5. Measurement shall be made of the actual quantities of those parts, notwithstanding local practice. The work shall be measured for the units mentioned in the Bill of Quantities according to the Contract as determined by the Engineer from approved drawings, Specifications and Contract Documents.

Whenever the Engineer requires any part of the Works to be measured, reasonable notice shall be given to the Contractor's Representative, who shall:

- (a) promptly either attend or send another qualified representative to assist the Engineer in making the measurement, and
- (b) supply any particulars requested by the Engineer.

If the Contractor fails to attend or send a representative, the measurement made by (or on behalf of) the Engineer shall be accepted as accurate.

**Delayed Payment**

In the first paragraph, second line, the words "compounded monthly" are deleted.

The text of 2nd paragraph is deleted in its entirety

Payment for the eligible work done will be made upto receipt of funds and no compensation/interests will be paid for any delay in payment.

"The Employer shall pay to the Contractor compensation at the rate of KIBOR+2% for local currency and LIBOR+1% for foreign currency per annum upon all sums unpaid within the period specified in Sub-Clause 14.7 [Payment]."

**Currencies of Payment**

The word "and" at the end of Sub-Para (ii) of paragraph (a) is deleted and the word "and" at the end of Sub-Paragraph (iii) is added.

The following paragraph is added after sub paragraph (iii):

- (iv) In case of Provisional Sum Item, payment will be made in the specified Contract currencies according to the actual expenditure in Local and Foreign currencies.

**Payment after Termination**

The following text is added at the end of Sub-Clause 15.4(c):

The Employer shall be entitled to sell any of the Contractor's Equipment, Temporary Works and unused materials and apply the proceeds of sale towards payment of any debt due from the Contractor to the Employer under this Clause including any outstanding payments to the subcontractors.

The following Sub-Clause is added after Sub-Clause 15.5:

**Corrupt or Fraudulent** For the purposes of this Sub-Clause:

**Practices**

“corrupt and fraudulent practices” includes the offering, giving, receiving, or soliciting of anything of value to influence the action of a public official or the supplier or contractor in the procurement process or in contract execution to the detriment of the procuring agencies; or misrepresentation of facts in order to influence a procurement process or the execution of a contract, collusive practices among bidders (prior to or after bid submission) designed to establish bid prices at artificial, non-competitive levels and to deprive the procuring agencies of the benefits of free and open competition and any request for, or solicitation of anything of value by any public official in the course of the exercise of his duty.

**Contractor’s Entitlement to Suspend Work**

In the first paragraph, fourth line, the period of notice of ‘21 days’ is changed to “56 days”.

**Termination by Contractor  
Consequences of  
Employer’s Risks**

The sub paragraph (h) of first paragraph is deleted in its entirety. In sub paragraph (b), the text appearing in first to last lines reading “In the case -----also be included.” is deleted.

**General Requirements for  
Insurances**

Under this Sub Clause the words ‘Insuring Party’ and ‘other Party’ wherever appearing are replaced with the expressions “the Contractor” and “the Employer” respectively.

The following Sub-clause is added after Sub-clause 18.4:

**Insurance Company  
Claims, Disputes and  
Arbitration**

The text “Dispute Board” is replaced with “**Adjudicator**” and “Dispute Board Decision” with “**Adjudicator’s Decision**” in this Clause 20.

The Sub Clauses 20. 2 to 20.4 are replaced with the following:

**Appointment of the  
Adjudicator**

Disputes shall be referred to the Adjudicator for decision in accordance with Sub-Clause 20.4 [Obtaining Adjudicator Decision].

The Parties shall appoint an Adjudicator by the date stated in the Contract Data. The Adjudicator shall be fluent in the language for communication defined in the Contract and a professional experienced in the type of construction involved in the Works and with the interpretation of contractual documents.

The terms of the remuneration of the Adjudicator, shall be mutually agreed upon by the Parties when agreeing the terms of appointment. Each Party shall be responsible for paying one-half of this remuneration.

If at any time the Parties so agree, they may jointly refer a matter to the Adjudicator for it to give its opinion. Neither Party shall consult the Adjudicator on any matter without the agreement of the other Party.

The appointment of the Adjudicator may be terminated by mutual agreement of both Parties, but not by the Employer or the Contractor acting alone. Unless otherwise agreed by both Parties, the appointment of the Adjudicator shall expire when the discharge referred to in Sub-Clause 14.12 [Discharge] shall have become effective.

**Failure to Agree on the  
Appointment or  
Replacement of  
Adjudicator**

If any of the following conditions apply, namely:

- a) the Parties fail to agree upon the appointment of the Adjudicator by the date stated in the second paragraph of Sub-Clause 20.2, [Appointment of the Adjudicator],
- b) the Parties fail to agree upon the appointment of a replacement person within 42 days after the date on

**Obtaining Adjudicator's Decision**

which the Adjudicator declines to act or is unable to act as a result of death, disability, resignation or termination of appointment,

then the appointing entity or official named in the Contract Data shall, upon the request of either or both of the Parties and after due consultation with both Parties, appoint a person as Adjudicator. This appointment shall be final and conclusive. Each Party shall be responsible for paying one-half of the remuneration of the appointing entity or official.

If a dispute (of any kind whatsoever) arises between the Parties in connection with, or arising out of, the Contract or the execution of the Works, including any dispute as to any certificate, determination, instruction, opinion or valuation of the Engineer, either Party may refer the dispute in writing to the Adjudicator for its decision, with copies to the other Party and the Engineer. Such reference shall state that it is given under this Sub-Clause.

Both Parties shall promptly make available to the Adjudicator all such additional information, further access to the Site, and appropriate facilities, as the Adjudicator may require for the purposes of making a decision on such dispute. The Adjudicator shall be deemed to be not acting as arbitrator(s).

Within 84 days after receiving such reference, or within such other period as may be proposed by the Adjudicator and approved by both Parties, the Adjudicator shall give its decision, which shall be reasoned and shall state that it is given under this Sub-Clause. The decision shall be binding on both Parties, who shall promptly give effect to it unless and until it shall be revised in an amicable settlement or an arbitral award as described below. Unless the Contract has already been abandoned, repudiated or terminated, the Contractor shall continue to proceed with the Works in accordance with the Contract.

If either Party is dissatisfied with the Adjudicator's decision, then either Party may, within 28 days after receiving the decision, give a Notice of Dissatisfaction to the other Party indicating its dissatisfaction and intention to commence arbitration. If the Adjudicator fails to give its decision within the period of 84 days (or as otherwise approved) after receiving such reference, then either Party may, within 28 days after this period has expired, give a Notice of Dissatisfaction to the other Party.

In either event, this Notice of Dissatisfaction shall state that it is given under this Sub-Clause, and shall set out the matter in dispute and the reason(s) for dissatisfaction. Except as stated in Sub-Clause 20.7 [Failure to Comply with Adjudicator's Decision] and Sub-Clause 20.8 [Expiry of Adjudicator's Appointment], neither Party shall be entitled to commence arbitration of a dispute unless a Notice of Dissatisfaction has been given in accordance with this Sub-Clause.

If the Adjudicator has given its decision as to a matter in dispute to both Parties, and no Notice of Dissatisfaction has been given by either Party within 28 days after it received the Adjudicator's decision, then the decision shall become final and binding upon both Parties.



The Sub Clauses 20. 6 to 20.8 are replaced with the following:

**Arbitration**

Any dispute between the Parties arising out of or in connection with the Contract not settled amicably in accordance with Sub-Clause 20.5 above and in respect of which the Adjudicator's decision (if any) has not become final and binding shall be finally settled by arbitration, specified in the Contract Data.

**Failure to Comply with Adjudicator's Decision**

In the event that a Party fails to comply with a final and binding Adjudicator decision, then the other Party may, without prejudice to any other rights it may have, refer the failure itself to arbitration under Sub-Clause 20.6 [Arbitration]. Sub-Clause 20.4 [Obtaining Adjudicator's Decision] and Sub-Clause 20.5 [Amicable Settlement] shall not apply to this reference.

**Expiry of Adjudicator's Appointment**

If a dispute arises between the Parties in connection with, or arising out of, the Contract or the execution of the Works and there is no Adjudicator in place, whether by reason of the expiry of the Adjudicator's appointment or otherwise:

- (a) Sub-Clause 20.4 [Obtaining Adjudicator's Decision] and Sub-Clause 20.5 [Amicable Settlement] shall not apply, and
- (b) the dispute may be referred directly to arbitration under Sub-Clause 20.6 [Arbitration].

The following Clauses are added after Clause 20

**Custom Duty**

*[Employer may incorporate provisions where applicable]*

**Taxes**

The Contractor, Subcontractors and their employees shall be liable to pay income tax, withholding tax, super tax and other taxes on income arising out of the Contract. The rates and prices as stated in the contract shall be deemed to cover all such taxes

**Integrity Part**

If the Contractor or any of his Subcontractors, agents or servants is found to have violated or involved in violation of the Integrity Pact signed by the Contractor then the Employer shall be entitled to :

- (a) recover from the Contractor an amount equivalent to ten times the sum of any commission, gratification, bribe, finder's fee or kickback given by the Contractor or any of his Subcontractors, agent or servants;
- (b) terminate the Contract; and
- (c) recover from the Contractor any loss or damage to the Employer as a result of such termination or of any other corrupt business practices of the Contractor or any of his Subcontractors, agent or servants.

The termination under Sub-Para (b) of this Sub-Clause shall proceed in the manner prescribed under Sub-Clause 15.1 to 15.4 and the payment under Sub-Clause 15.4 shall be made after having deducted the amounts due to the Employer under Sub-Para(a) and (c) of this Sub-Clause.

**SPECIFICATIONS  
SPECIAL PROVISIONS**

### TABLE OF CONTENTS OF SPECIAL PROVISIONS

SP. No.	Description
SP-1	The Site
SP-2	Work Under the Contract
SP-3	Work by Others
SP-4	Project Features
SP-5	Supply of Plant and Installation Services
SP-6	Drawings
SP-7	Physical and Other Data Available to Contractor
SP-8	Layout of Work and Surveys
SP-9	Approval of Materials and Equipment
SP-10	Contractor's Quality Assurance Plan
SP-11	Construction Schedule
SP-12	Facilities Provided by the Employer
SP-13	Construction Camps and Colonies
SP-14	Other Facilities for Engineer's and Employer's Personnel
SP-15	Equipment Furnished by the Employer
SP-16	Cooperation with other Contractors
SP-17	Safety and Health
SP-18	Construction Utilities
SP-19	Traffic, Roads, Bridges and Telecommunication Equipments
SP-20	General Mechanical Requirements
SP-21	General Electrical Requirements
SP-22	Environmental Protection
SP-23	Standards of Countries other than those Specified
SP-24	Progress Reports and Photographs

<b>Sp. No.</b>	<b>Description</b>
SP-25	Unit Price Breakdown
SP-26	Transport and Handling of Cargo
SP-27	Directed and Required
SP-28	Communications to the Engineer
SP-29	Any Other Provision
SP-30	Measurement and Payment – General
SP-31	Measurement and Payment

**[Note:**

*The above Sections of Spicification, are for guidance only, and shall be indicated appropriate to the work/project.*

*The User may adopt the above format. However, if any section is not applicable, it may be mentioned as “Not Used”. ]*

---

**SPECIFICATIONS  
TECHNICAL PROVISIONS**

---

## SPECIFICATIONS

### **Updated Specification for Standardization Panel and Allied Equipment for Khyber Pakhtunkhwa**

#### 1. SOLAR PANELS

- > The Solar Panel shall meet the requirement set in IEC 61215:2016 or IEC 61215--2005 , IEC61730-1:2004 or latest and IEC 61730- 2:2004 or latest, IEC 61701(latest), / international standards.
  - > Solar Panels with Anti-PID Certification based on IEC standard TS-62804-1 will be preferred (i.e: TUV PPP-58042).
  - > The manufacturer name and date of manufacturing of solar panel in a definite pattern i.e, DD/MM/YYYY should be laminated inside front glass. The PV Module not more than one (1) year old.
  - > Outstanding conversion efficiency. (Module efficiency minimum 16.5% or higher)
  - > More Power per square meter than other panels.
  - > Positive watt class rating/positive power tolerance (+3 to +5 watt above industry average.
  - > Low temperature coefficient.
  - > PID degradation free.
  - > The PV module(s) shall contain mono crystalline silicon, Grade-A Solar cells. (Only Monocrystalline or higher efficient will be preferred)
  - > The PV module have an ability to Works well with high-voltage input Inverters/ charge controllers (1000 Vdc)
  - > The PV Panel must have clear anodized aluminum frame with Anti-reflection cover glass.
  - > Maximum bus bars. (Minimum 3 numbers of bus bars)
  - > Special glass etching and anti-reflective coating.
  - > Solid Warranty, stable and well established company.
  - > Ammonia and salt mist corrosion resistance.
  - > Tier 1 solar panel producer (Tier 1 or Financial Strong manufacture should be certified and listed with third party insurance company providing worldwide coverage such as SolarIF, PowerGaurd etc or equivalent.
  - > Fully automated production cycle, reducing sources of variation in production. Manufacturer should have their own in-house solar cell and solar panel manufacturer facility.
  - > Extremely low failure rate.
  - > Multi award winning company. (will be preferred)
  - > Test Standard(s) to which the module has been tested and certified.
  - I-V curve for the solar photovoltaic module/panel.
- Date and year of obtaining IEC PV module standardization qualification certificate.

- Electrical Data at nominal Cell Operating Temperature (NOCT).
- PV Module efficiency at STC.
- Following information should be labeled on the solar panels and should be provided in the data sheet:
  - Test Standards to which the module has been tested and certified. • IEC PV Module standardization qualification certificate. • Electrical Data at nominal Standard Testing Conditions (STC) • Electrical Data at nominal cell operating temperature (NOCT) • PV module Efficiency.

> Each panel should have factory equipped weather proof terminal junction box having at least IP65 protection with provision of opening for replacement of DC cables, blocking diodes and easy debugging if necessary.

> /25 years performance warranty for 80 % output power.

> Certified with high wind speed. (Minimum wind load capacity = 3.8 KPa and snow load capacity of 5.4 KPa)

> Flash test reports from manufacturer for each panel given for sample.

> All information regarding solar panel with above mentioned featured data should be accessible and verifiable online on manufacturer website or verifiable in writing from manufacturer through fast track courier (Note the courier charges etc, for such verification will be borne by the supplier.)

## 2. WATER PUMPING INVERTERS / CONTROLLER:

The solar pump inverter/controller should have built-in MPPT controller, over load protection, Soft start/Soft Stop Features and Variable Frequency Drive (VFD) with integrated Gate Bipolar Transistors. The inverter offered should comply to or Equivalent standards:

> CE/RoHS/international standards (ISO 14001, OHSAS 18001 applicable)

> Low Voltage Directive 2014/35/EU with Supplements

> EMC Directive 2004/108/EC with Supplements

The complete datasheet showing all the electrical parameters like input & output voltage ranges should be provided in the technical bid. All the electrical parameters like input & output voltage ranges, and efficiency should be provided at the time of pre-supply testing and inspection. Efficiency of inverter should be 92% and above.

- Rated output voltage of inverter / Controller shall be pure sine wave AC. Total harmonic distortion in AC output should not exceed 2%.

- Inverter should have at least three (3) years extendable to 10 years performance warranty.

- Inverter circuit must include protection against:

Over or Low voltages and currents beyond critical level of the inverters circuits.

> Protection against accidental short circuits & reverse polarity connections.

> Protection against lightning induced transients.

> Over load protection.

> Low RPM Protection (i.e: Frequency < 30 Hz) Motor Should Stop.

---

> Dry run protection.

• dV/dT Filters With Inverter (VFD):

> The use of load reactors increases the reliability, performance, and efficiency of VFD systems, extends the life of both drives and motors, and reduces the amount of energy consumed by the motor/drive system.

> Output dV/dT or Sine Filters (between VFD and Motor) of appropriate size should be used where the motor cable length is more than Fifty (50) Feet or as advised / recommended by the inverter manufacturer in their Technical Documentation.

> dV/dT Filter should be enclosed in a box.

3. GRID TIE INVERTER  UL-1741 Certified  98% Conversion Efficiency  Pure Sine wave output  True three-phase bridge topology for DC/AC output converter– Transformer-less topology  Each inverter is set on specific grid codes which can be selected in the field  Detachable wiring box to allow an easy installation  Wide input voltage range  Electrolyte-free power converter to further increase the life expectancy and long term reliability  Integrated string combiner with different options of configuration which include DC and AC disconnect switch in compliance with international standards (-S2, -S2F and -S2X versions)  Natural convection cooling for maximum reliability  Outdoor enclosure for unrestricted use under any environmental conditions  Availability of auxiliary DC output voltage (24 V, 300 mA)  Capability to connect external sensors for monitoring environmental conditions.

HYBRID /OFF GRID INVERTERS: i) UL 1741, IEC 61683, IEC 62109-1 and IEC 62109-2, EN 50524, EN 50530. ii) The DC power produced is fed to inverter for conversion into AC. In a grid interactive system AC power should be fed to the grid at three phase 415 AC bus. iii) Power generated from the solar system during the daytime is utilized fully by powering the critical building loads and feeding excess power to the grid as long as grid is available. In cases, where solar power is not sufficient due to more demand or cloud cover etc. the building loads should be served by drawing power from the grid. The inverter should always give preference to the Solar Power and will use Grid/DG power only when the Solar Power is insufficient to meet the load requirement. iv) The output of the inverter must synchronize automatically its AC output to the exact AC voltage and frequency of the grid. v) The offered On-Grid Inverter must be of Hybrid type has an ability to synchronize with battery bank as backup system. vi) Inverter should continuously monitor the condition of the grid and in the event of grid failure; the inverter automatically switches to off-grid supply within 20-50 milliseconds and synchronize with battery bank and fulfil shortcoming from battery bank as PV-Battery hybrid system. The solar system is resynchronized with the grid within two minutes after the restoration of grid or DG set. vii) Grid voltage should also be continuously monitored and in the event of voltage going below a pre-set value and above a pre-set value, the solar system should be disconnected from the grid within the set time. Both over voltage and under voltage relays should have adjustable voltage (50% to 130%) and time settings (0 to 5 seconds). viii) Metal Oxide Varistors ( MOVs) should also be provided on DC and AC side of the inverter. ix) The inverter



control unit should be so designed so as to operate the PV system near its maximum Power Point (MPP), the operating point where the combined values of the current and voltage of the solar modules result in a maximum power output. x) The inverter should be a true sine wave inverter for a grid interactive PV system. xi) The degree of protection of the outdoor inverter panel should be at least IP-55. xii) Typical technical features of the suggested inverters must mention as per following sequence.

Continuous output power rating (1.1 times for 60seconds)  Nominal AC output voltage and frequency  Accuracy of AC voltage control  $\pm 1\%$   Accuracy of frequency control  $\pm 0.5\%$   Grid Frequency Control range  $\pm 3$  Hz  Maximum Input DC Voltage range  MPPT Range DC  Ambient temperature -10 deg C to 55 deg C  Humidity 95 % non- condensing  Protection of Enclosure IP-55 (minimum)

Grid Voltage tolerance -20 % and + 15 %  Power factor control 0.95 inductive to 0.95 capacitive  No-load losses < 1% of rated power  Inverter efficiency (minimum) 95%  TUV certified, Warranty 5 years.  Liquid crystal display should at least be provided on the inverters front panel or on separate data logging/display device to display following

a. DC Input Voltage

b. DC Input current

c. AC Power output(kW)

d. Current time and date

e. Time active

f. Time disabled

g. Time Idle

h. Temperatures (C)

i. Converter status  Following should also be displayed like Protective function limits, Over voltage, AC under voltage, Over frequency, under frequency, ground fault, PV starting voltage, PV stopping voltage, over voltage delay, under voltage delay over frequency, ground fault delay, PV starting delay, PV stopping delay.)

5. Cable and DC Wiring for Water Pumping system:

> The AC / DC cables should be made of 99.9% copper strands and Flexible. > The DC cable must have double insulation suitable for 1000 VDC transmission. > DC circuit breakers (not fuse) of at least 800V and suitable ampere rating must be installed between PV modules and PV pump controller in order to avoid short circuiting.

> AC Circuit Breaker of suitable rating must be installed between Pump Controller and Motor.

> DC Breaker, AC Breaker and Inverter / Controller should be placed in an enclosure of IP55 standard.

> Cables shall be clearly labelled with essential electrical parameters including manufacturer name, Voltage Range, standards etc.

> All wiring shall be aesthetically neat and clean, over all wiring/connection losses shall not exceed 1% of the total rated output power.

---

> All connections/ socket outlet among array, controller, inverters, batteries, and pumping set etc must be made in junction boxes of adequate protection level.

> All wires/cables should be in standard flexible UV-Resistant conduits for outdoor installation and HDPE pipes (3 feet deep) for underground wiring and PVC ducts for indoor installation.

#### 6. Panel Mounting and Structure:

> The panel mounting and structure should be made of hot dipped (80 microns minimum) galvanized steel of minimum thickness of 2.64 mm / 12 Gauge Channel A sketch of the mounting frame (As per Actual Site Requirements) showing dimensions of the frame parts should be provided at the time of supply.

> PV to ground clearance must not be less than 2 feet. The height of the upper edge of the structure should not exceed 10 ft above the ground and 6 Feet for roof.

> To avoid Shading, Distance between two rows of PV panels and from walls should be maintained at a minimum of 1.6 times the height of structure/walls.

> The pit size for concrete works should be minimum 1.5x1.5x2 ft for each leg and the concrete should be extended at least 1 ft above the ground. The concrete ratio should be 1:2:4. > The Surface azimuth angle of PV Module 180o and the Tilt angle (slope) of PV Module should be 33o.

> The PV modules will be mounted on metallic structures of adequate strength and appropriate design, which can withstand load of modules and high wind velocities up to 150 km per hour.

#### 7. Solar Auto Trackers for Water pumping system:

The solar tracker offered should be fully automatic and intelligent, and must be capable of Single axis tracking (from east to West) and should have its own power supply (PV Panel, Battery and Charge Controllers) other than PV Panel used for Pumping Setup.

Individual Auto-Tracker should not be less than 4kW each.

The auto Tracker should also have manual control mode to adjust the tracking angle manually. Structure Material Should be Hot Dipped Galvanized Steel (Minimum 80 Microns).

All nuts, bolts, washers and other fasteners for mounting structure shall be made of minimum A2 grade stainless steel.

Foundation and other details will be separately provided. 03 years Comprehensive Free Replacement, Repair and maintenance Warranty (Free of Cost) should be provided for all the components of auto Tracker (including Batteries).

#### 8. BATTERIES:

> The battery should be maintenance free, Deep Cycle, Tubular, OPzV Type. (AGM, GEL, LI ion, Lead corban)

> The battery must ensure safe and reliable operation in the whole range of ambient temperatures from -5° C to + 50° C.

> The maximum permissible self-discharge rate should not be more than 5 percent of rated capacity per month at 25° C.

## Specifications

---

- > Cycle life of the battery minimum 3000 @ DOD 80 % for lithium Ion, 1800 @ 30% DoD for Gel/AGM and 4000 cycles @ 40% DoD for Lead Carbon & OPzV
- > Battery should have maximum discharge rate.
- > The battery shall have a certificate of compliances, issued by a recognized laboratory.
- > The Batteries should have minimum 5 to 10 years float life.
- > The battery shall meet the requirements and recommendations given in IEC 60896 21/22 or equivalent.

### 9. LED LIGHTS:

- > Solar Based LEDs/Light fixtures shall conform to the latest IEC/ISO internationally recognized standards.
- > LEDs/Light fixtures should not be Chip-on-board (COB) single chip type due to their poor heat dissipation.
- > LEDs/Light fixtures shall be modular type with proper heat sinks.
- > Solar based lights (LED fixtures etc) should provide at least 100 Lumen/watt.
- > LEDs/Light fixtures should be designed to deliver at least 10 years of service.
- > Complete lightening unit shall be weather proof (Protection Class IP65).
- > The output from the LEDs/Light fixtures should be constant throughout the duty cycle. > The LED lights should have minimum 10,000 duty hours.

10. Water Pump  
Internationally certified. Pump should be supplied having standard ISO-9906 specifications. The pump must be submersible, made of stainless steel. The characteristic curves (Original from Manufacturer) showing the efficiency at duty point and performance of the pump should be provided in the technical proposal and also at the time of pre-supply testing. The quoted pump should be tested for its performance and certified as per ISO-9906 Grade-1 standard. The pump should be suitable for installation and operation in tube wells/dug wells/open well with clear water discharge. Pump shall comprise off bowl assembly and non-return valve as integral part of pump's parts. Pump and motor shall rigidly couple through NEMA standard coupling. Each stage casing must have replaceable wear ring. The impellers shall be secured to the pump shaft with tapered conical sleeves pressed into the taper bore of impeller or impeller secured through chrome plated stainless steel hexagonal sleeves. Suction casing must be between pump and motor with suction strainer as protection of pump against coarse impurities of the liquid handled.

### Specification for main components of the Pumps:

S.NO	Components	Specifications
1	Casing/Diffuser	The Casing/Diffuser should be in fabricated stainless steel AISI 304.
2	Impellers	stainless steel AISI 304
3	Driving Shaft	Stainless steel 304/420
4	Sleeves	Stainless steel AISI 329/ 30

5	Gaskets	Rubber Gaskets
6	Bearings	AISI 304/316/329/420
7	Coupling & Screen + Cable Guard	Stainless steel AISI 316/319/304/420
8	Non-Return Valve / Sluice Valve	As per British standard specifications (BSS), Minimum 16 bar pressure sustaining design
9	Pressure Gauge	As per British standard specifications (BSS), having PSI or Bar scale
10	Clamps	Steel – Pressed
11	Pump Efficiency	Minimum efficiency of the pump should be 70% ensured at duty point (it's Not applicable for Less than 2800 IGPH). (Duty Point of the Pump should always be selected to the right of Pump Peak efficiency Point)

#### 11. Water Motor

Internationally certified. The winding material should be 99.99% copper. The motor should have wet type, water cool rewind-able/repairable stator. The motor should have non-disposable/nonhermetically sealed winding. The insulation class of the winding material should be mentioned. For each model quoted, all the technical parameters such as rated voltage, power factor, efficiency, full load ampere, speed and other similar parameters should be provided at the time of pre-supply testing. The testing report with all basic parameters should also be provided at the time of pre-supply testing.

The motor shall be manufactured in compliance with National Electrical Manufacturer Association (NEMA) standards. The motor shall be three-phase submersible and shall be capable of operating at rated voltage of 380 Volts at 50 Hz. The motor should be capable of operating with variable speed through V/F control. Winding of the motor shall of rewind able type with class - IC40 insulation and IP68 protection. The synchronous speed should be 2850-2950 RPM. Motor shall be capable of operating in well water with temperature normally start from 40C. Motor should be designed for continuous operation. Motor must be filled with water without any chemical additives hazards to health for cooling. The motor must be properly protected against the entry of well water sand etc by double mechanical seal one is rotating and other stationary and must be made of Silicon carbide/ Tungsten carbide and must be protected with sand protection guards. All supports shall be high grade cast iron and stator outer side jacket body should be in stainless steel in AISI 304. The excessive pressure due to heating up of the filled water must be compensated by a pressure equalizing rubber diaphragm in the lower part of the motor. The axial thrust of the pump shall be countered by oscillating sliding block type thrust bearing. The thrust bearing of the motor should be able to bear a download thrust force from the water pump and the upward thrust force produced while starting the

## Specifications

water pump. Motor shall be capable of maximum of 20 starts in an hour. Motor efficiency above 7.5 HP should not be less than 75% for and less than 7.5 HP should not be less than 70% at Motor Rated Voltage.

Technical specification of rewind-able wet stators, three phase squirrel cage water filled submersible motor.

S.No	Components	Specification
1	Winding	Made of pure electrolyte copper a non-hygroscopic poly vinyl chloride for normal temperature and must full fill resistant tests
2	Stator	Energy efficient low-losses electrical magnetic sheet should be fixed in stainless steel casing. M800 or M600 magnetic sheet are preferable to
3	Rotor	Energy efficient low-losses electrical magnetic sheet fixed with high grade copper bars. M800 or M600 magnetic sheets are preferable to
4	Spline Shaft	AISI 420 stainless steel, flange dimension according to NEMA standard, over size design to ensure stiffness in severs condition.
5	Shaft bearing	Water lubricated guide/general bearings fixed in upper and lower brackets should be made of metal impregnated carbon.
6	Lower thrust bearing	Thrust sliding block bearings, self-aligning Mitchell type, should be able withstand 15500N/20000N axial load.
7	Mechanical Seal (Stationary & Rotary)	Silicon carbide or tungsten carbide mechanical seal.
8	Cooling filling fluid	Water mixed with non-toxic anti-freeze provides cooling and lubrication also protects and prevent inside parts from corrosion.
9	Degree of protection	IP68
10	Insulation of Class	With winding wire poly vinyl chloride up to 70 degree C with winding wire polyethylene up to 95 degree C.
11	Voltage Tolerance	-6% to -10%
12	Mounting position	Vertical horizontal
13	Class	IC40
14	Maximum Immersion	150 Meters
15	Stating per hour	20

### 12. SUBMERSIBLE FLATE ELECTRIC CABLE:

The submersible cable should be made of 99.9% copper strands with double PVC insulation for 1000Vac, should be adequately flexible and environment friendly. Stranded and flexible insulated copper wires and cables must be used for all outdoor and indoor installations. The wiring that leads into the building shall be protected in a conduit. The cable must have undergone quality tests as per BSS standards. Following lab tests are mandatory.

- Conductor resistance test.

- 
- Insulation resistance test.
  - Pressure test.
  - Spark test.
  - Note: The Supplier should provide the quality tests certificates at the time of presupply testing and inspection.

### 13. COLUMN PIPE:

The column pipe shall be flanged ERW steel pipes conforming to ASTM designation A-53 with a minimum thickness of 3.5 mm and shall be painted with corrosion resistance paint of suitable thickness. Flanges thickness of 20 mm shall have grooves for cable passage. Each column pipe shall be complete with gaskets, bolts/studs, washers and nuts. All nuts, bolts, and washers shall be made of minimum A2 grade stainless steel.

The column pipe shall be supplied in interchangeable section having an approximate length of 10 feet column pipe shall be flanged perpendicular to the axis of pipe.

HDPE Pipe of 1 or 0.75 Inch diameter conforming to ASTM F-2160 Standard without Joints to be installed/included along with and equal to Column pipe for confirming Water Level testing purpose.

### FEATURES:

- Manufacturer's pipes should meet international standards like BSEN 10255 & ASTM A 53.
- Dimensional accuracy circularity and plan end cut should be observed,
- Weld strength of pipe and mechanical properties or raw material should be tested as per manufacturing standards.
- Pipes should be NDT tested (Non-destructive - Eddy current)
- Pipes should be hydrostatically pressure as per manufacturing standard.
- Pipes should be gone through straightening process to remove bendiness.

### 14. TOPSET Water Pumping system:

Top set shall comprise of Bore covers plate, (covering bore hole completely and securely), installation/suspension clamps, sluice valve, reflex valve, Washout Valve 4 feet above the ground (T-Connection For Testing Pump's discharge), connector and cable jointing material (Cable connection from motor to switching device shall be joint free) pressure gauge and cable ties. Bore Cover Plate should have provision for water level testing facility (i.e: Hole for Sonic Water Level Meter / HDPE Pipe insertion)

For Cleaning of solar Panels, Plastic pressure pipe should be provided of suitable length to reach the furthest / last Solar Panel.

Every Water Supply Scheme should have a non-removable name plate fitted at inverter box having essential information and bearing the name of supplier and client.

### 15. DC Solar Water Pump:

The equipment must be internationally certified. DC motor brushless, Built inside a cast stainless steel housing. High power rare earth (neodymium) permanent magnets to provide high torque for maximum performance. Driven by a PWM signal from the controller. The PWM signal ensures a soft

start and infinite speed control of the motor. Only non-corrodible materials are used, motor windings are cast in resin to provide a very long life, even in difficult conditions.

Control equipment must:  be separate from the other system components.  provide direct solar connection as standard.  have the ability to add on an optional power pack if required in the future.  provide diagnostic indicators to show status  have provision for continuous performance measurement  have provision for continuous performance measurement.

Control equipment includes monitoring, power conversion, MPPT (Maximum PowerPoint Tracking) sensors, Software base commission, Mobile Software, Storage data option, frequency control and other equipment related to the solar pumping system.

16. LED SOLAR STREET LIGHTNING SYSTEM:  Must be certified internationally.  The W-LED solar lightning system should be designed to operate from dusk to dawn (more than 14 hours)  The Light source should be white type.  Color LED used in the system should be in the range of 5500 K to 6500 K (Cool White)  LED emits ultra violet light is not permitted.  The light output source should be constant.  Luminous flux should be 4000 lumens with permissible allowance of 10 %.  The outdoor housing or luminaries should be all weather proof.  Heat sink temperature should not increase more than 20 degree centigrade above ambient temperature.  The charge controller must ensure safe and reliable operation in the whole range of ambient temperature from -20 to +50 degree centigrade.  The make, model number and country of origin should be mentioned.

The performance warranty should cover at least 3 years for replacement upon defect/malfunctioning.

17. SMD LIGHTS Must be internationally certified. Modular design, matrix array, light uniformity. Excellent heat dissipation performance, guarantee lamp long lifespan. Light effect soft and comfortable, no glare. Original chip, high luminous efficiency, long lifespan, good stability, high reliability. No mercury, lead and other hazardous materials, RoHs compliant. Support several intelligent dimming modes, energy conservation. Be used on corridors, inside rooms etc.  A unique, modular design with enhanced optic-lense makes this IP66-rated area luminaire the most versatile to date, providing exceptional lighting performance and reduced total cost of ownership in variety of applications. The modular design accommodates up LEDs to allow for customization of illumination and economic performance for a wide range of applications. The advanced thermal management system contributes to unparalleled lumen maintenance.

18. Solar Charge Controller: The product must have certification of CE, LVD, EMC, ISO 9001, ISO 14001 and ROHS. Certificates must be attached. • Charge controller must have MPPT technology. • Must have minimum 98 % tracking efficiency. • Conversion efficiency minimum 95 %. • Controller must have user time function to control the working hours of the • light. • Must have load control. • Must have heat sink to dissipate excessive heat. • Must have temperature compensation for charging batteries in higher • temperatures. • The charge controller must have protection for reverse flow of current through • the PV modules. • Charge controller must have PV short circuit, PV reverse polarity, PV over • voltage, PV over current, battery over charging, battery over discharging, battery reverse polarity, load short circuit and load over protection.

19. Energy Efficient Fans: Must be internationally certified. ISO/IEC/ or equivalent.

---

20. LIST OF APPROVED LABORATORIES: □ Fraunhofer ISE ( Freiburg Germany) □ European Solar Test installation Renewable Energies Unit Institute for Environmental and Sustainability-JRC (Italy) □ NREL –National Renewable Energy Laboratory (USA) □ Arizona State University Photovoltaic Testing Laboratory (USA)

Centro de Investigaciones Energeticas medio ambientales y tecnologicas Centro de La (Madrid Spain) □ TUV Rheinland/SUD/Nord Product safety GmbH (Germany) □ Post and Telecommunications Industry Products Quality surveillance and inspection center PTPIC (Beijing China)

21. The authorized dealer must attach List of clients/customers to whom the equipment delivered.

## **SPECIFICATION FOR THE SUPPLY AND INSTALLATION OF SOLAR BASED PUMPING UNITS**

### **1. SOLAR PANELS:**

#### **1.1 Solar cell type:**

The photovoltaic cell should use technology of Mono Crystalline Silicon Cell with high efficiency and the w module efficiency should be minimum 17% or above. More power per square meter than other panel. Low temperature coefficient. The PV modulus have an ability to works well with high voltage input inverter/charger controllers (1000 Vdc). Fully automated production cycle, reducing sources of variation in production, Manufacturer should have their own in house solar cell and solar panel manufacturer facility. Multi award winning company should preferred.

#### **1.2 Protections:**

Panel should have series fuse rating of 15 Amp with a bypass diodes for reverse current protection. Junction box should be there with water resistant capability. Ingress protection of panel should be at least IP-65. Cable connectors should be ingress protected by at least IP-67 with application classification of class A. Panel should have capability to sustain its functionality with wind load of at least **3.8 KPa** & Robust frame up to **5400 Pa** snow load. Ammonia and salt mist corrosion resistance.

#### **1.3 Material & finishing:**

The encapsulation material must be Ethylene Vinyl Acetate (EVA) and its lamination with temperature safety glass. Special glass etching and anti-reflective coating.

#### **1.4 Traceability:**

A strip containing Serial number should be laminated inside the module so as to be clearly visible from front side.

#### **1.5 Life Time and Warranty:**

The PV cells should be designed for more than 25 years of its life with power decrease of not more than 20% after completion of 20 years. Solar panel should have at least 20 years of guarantee with all its subsystem. The PV module offered should not be more than one (01) year old with respect to the date of manufacturing. Unique Serial No of PV Modules and date (DD/MM/YYYY) of manufacturing should be laminated inside of the module to make it clearly visible from the front side. Brand name of PV modules, the supplier intends to supply must be included in the technical proposal.

#### **1.6 Wiring:**

Panel wire should be specifically designed for solar usage with Plug and play connectors. Wiring should have compatibility of field serviceable contact removal.

#### **1.7 PID Free Certification:**

Potential Induced Degradation (PID) refers to potential induced performance degradation in crystalline photovoltaic modules. It occurs when the module's voltage potential and leakage



current cause ion mobility within the module. The degradation accelerates with exposure to humidity, temperature and voltage potential. Consequently, PID can have a profound adverse effect on the financing and operation of PV plants. PID tests simulate the practical conditions in the PV system, and verify the module performance and power output under high voltage and temperatures.

**1.8 Standard Conformity:**

The PV module should fully conform to following specifications.

- IEC 61215-1 : 2016
- IEC 61215-1-1 : 2016
- IEC 61215-2 : 2016
- IEC 61730-1 : 2016
- IEC 61730-2 : 2016
- IEC-61701(latest).
- IEC-62716.
- IEC-60068-2-68.
- PPP58042

**1.9 Submittals:**

Following details should be provided in Technical Bid otherwise bidder will not eligible for further evaluation:

- PID Free Certificate from TUV.
- TUV certification of IEC-61215:2016 and IEC-61730: 2016 Conformity.
- I-V curve for solar photovoltaic module panel.
- PV module efficiency at STC.

Note: All above mentioned certificate must be provided for offered panel and all information regarding solar panel with above mentioned featured data,EL and Flush test report from manufacturer for each panel should be accessible and verifiable online on manufacturer website or verifiable in writing from the manufacturer through fast track courier.

**2. INVERTER/CONTROLLER:**

The solar pump controller should have built-in MPPT controller, Voltage Frequency (V/F) regulation, over load protection, soft start/ soft stop features and variable frequency Drive (VFD) with integrated Gate Bipolar transistors. The make and origin of the inverter/controller should be of Japanese and European origin or approved equivalent and clearly mentioned in the technical proposal. The inverter offered should comply to or equivalent standards:

- CE/ROHS/international standards (ISO 14001, OHSAS 18001 applicable).
- Low Voltage Directive 2014/35/EU with supplements.
- EMC Directive 2004/108/EU with supplements.
- The efficiency of inverter should be 92% and above.
- Inverter should have at least three (3) years extendable to 10 years' performance warranty.

**2.1 Inverter circuit must include protection against:**

- Over or low voltages and currents beyond critical level of the inverters circuits.
- Protection against accidental short circuits & reverse polarity connections.
- Over load protection.
- Low RPM protection (i-e: efficiency < 30 Hz) Motor should be stop.
- Dry run protection.

**2.2 Submittals:**

Following details should be provided with the tender submission.

- LVD certificate
- Origin country Certificate for module quality
- CE marking
- Test report for weather-Proof Test (IP65)

The complete datasheet showing all the electrical parameters like input & output voltage ranges should be provided in the technical bid.

### 3. MOUNTING STRUCTURE:

The panel mounting structure should be made of hot dipped galvanized steel pipes, or epoxy coated mild steel pipes (minimum wall thickness 2.5 mm) and should have the provision for vertical (east to west) automatic Sun-Tracking by slewing drive. A sketch of the mounting frame showing dimensions of the frame parts should be provided in the technical proposal.

### 4. AUTO SUN TRACKING SYSTEM:

The tracker offered should be fabricated from GI pipes or channels having minimum wall thickness of 2.6 mm. It should have large mounting capacity 4000 Wp to 5500 Wp in order to achieve better land area utilization. The tracker offered should have robust structure capable of withstanding 150 km/hr wind speed. The tracker structure should rest on standard 9-Inch gear drive/ slewing drive having following minimum specifications. Three years' comprehensive free replacement, repair and maintenance warranty (Free of cost) should be provided for all components of auto tracker (including Batteries).

Detail catalog showing material specifications, load characteristics, make & origin of the slewing Drive and rated speed, voltage and power of the DC motor used must be provided in the Technical Proposal.

<i>Slewing Drive Performance Data</i>		
Rated Output Speed	0.049 rpm	
Rated Output Torque	805.2 kN.m	595.8 lbf.ft
Tilting Moment Torque (Max.)	33.9 kN.m	25×10 <sup>3</sup> lbf.ft
Holding Torque	38.7 kN.m	29×10 <sup>3</sup> lbf.ft
Axial Load (Max.)	338 kN	76×10 <sup>3</sup> lbf
Radial Load (Max.)	135 kN	30×10 <sup>3</sup> lbf
Ratio of Worm Gear	61:1	
Tracking Precision	≤ 0.17°	

The tilting moment/ axial load characteristics should meet or exceed the following

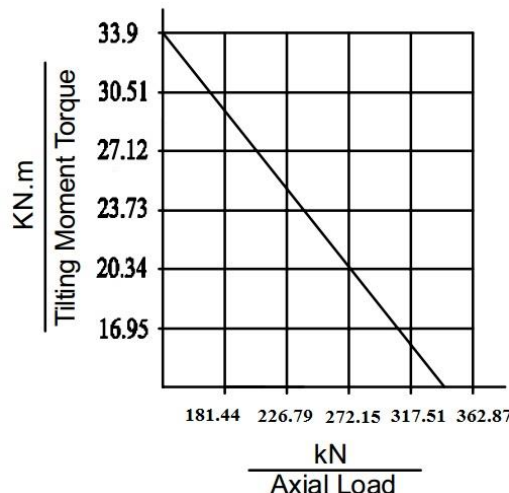

The slewing drive offered should be maintenance free. The drive control should be fully autonomous and based on real time sun sensing (not timer based control). There should be

**Specifications**

safety limit switches to restrict the movement of tracker. The control should have protection for tracker overloading due to jamming and or other reason. There should be provision for manual movement of tracker. Reference drawings showing concrete plan, general dimensions and slewing drive size are enclosed herewith.

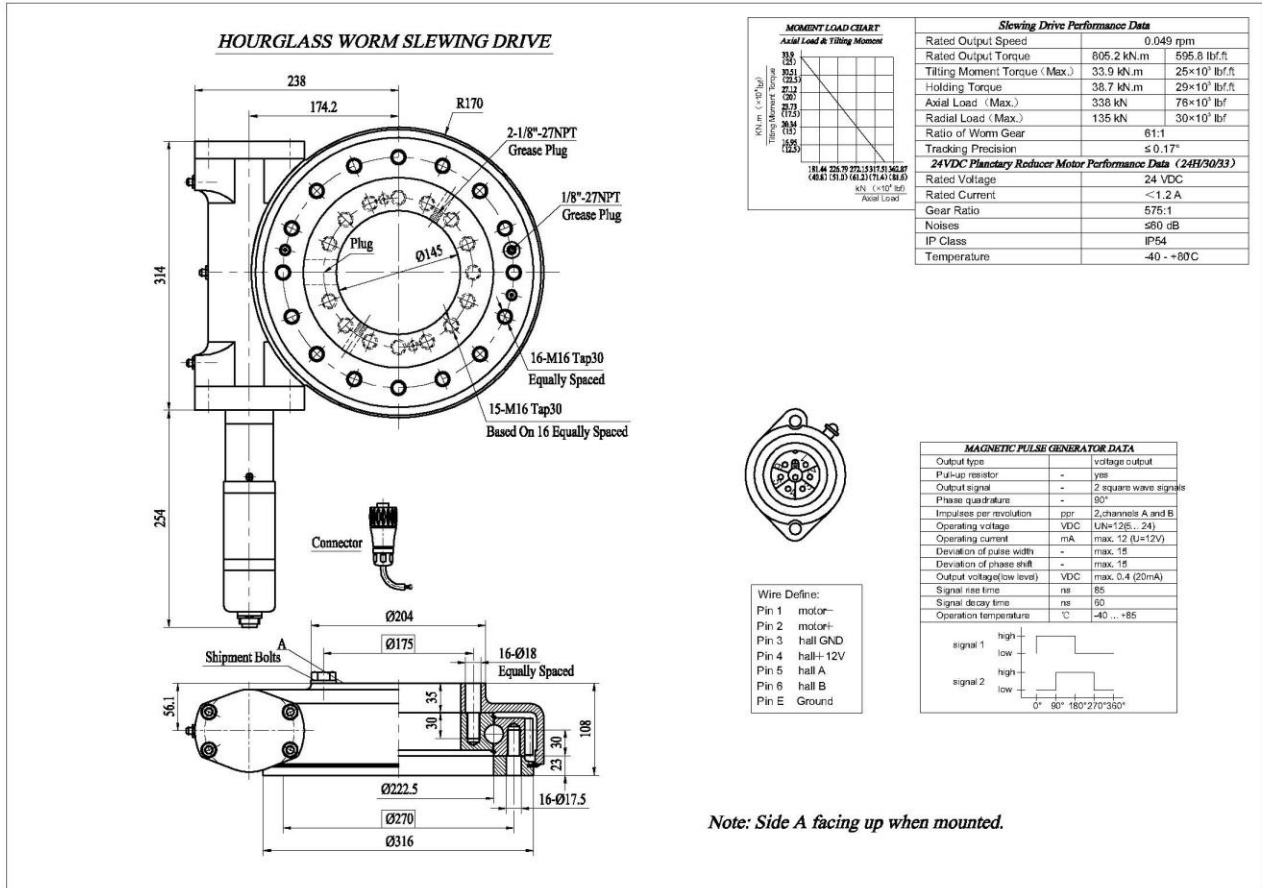

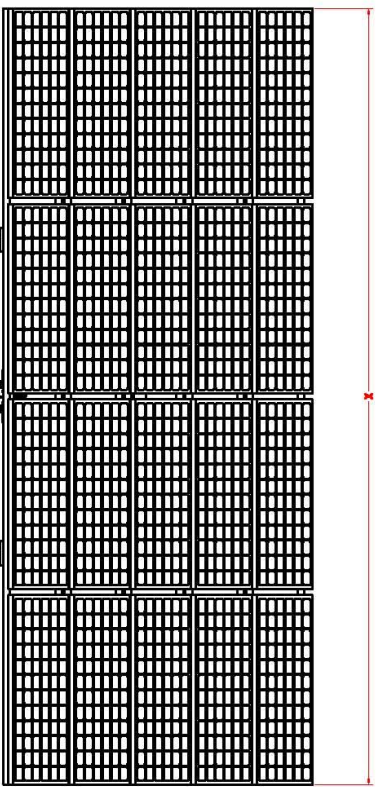
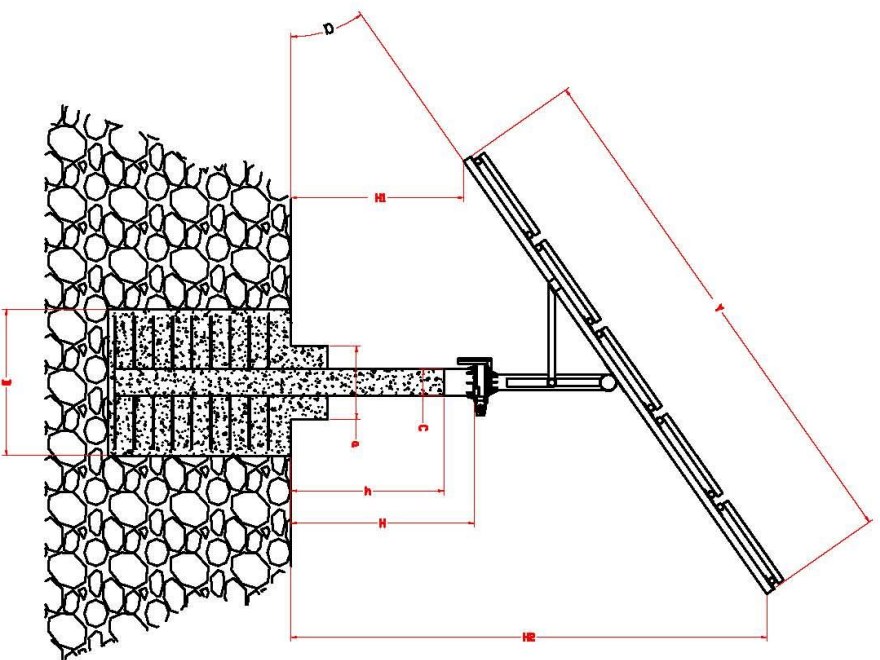

■ SOIL /GRAVEL  
 ■ CONCRETE (12:4)  
 ■ STEEL

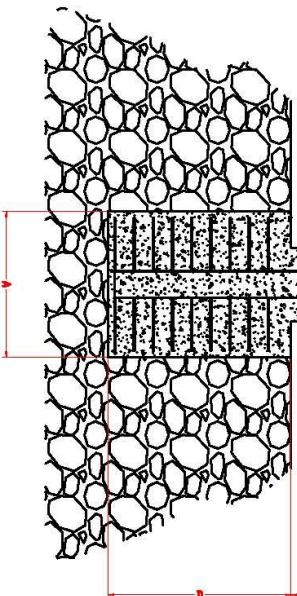

General Dimensions and Concrete Plan of Single Pole PV Mounting Structure with Single Axis Tracking System

Sr. No.	Type/Size	X (ft)	Y (ft)	H1 (ft)	H2 (ft)	a	A (ft)	B (ft)	D (ft)	a (ft)	b (ft)	d (ft)	C (in)	H (ft)	h (ft)
1	5/72x20	20.7	13.25	>3	12	30-36	4	4	5.5	2	2	1	8	4.5	4
2	5/72x21	18.5	15.55	>3	12	30-36	4	4	5.5	2	2	1	8	4.5	4
3	6/60x18	19.52	16.10	>3	12	30-36	4	4	5.5	2	2	1	8	4.5	4
4	6/60x20	21.5	16.27	>3	12	30-36	4	4	5.5	2	2	1	8	4.5	4

## 5. SYSTEM DESIGN/SIZING:

De-rating factors should be applied while designing the system in order to have compensations for variations in irradiance. The motor output (BHP) should be at least **20%** more than the pump required input power (Shaft Power). Also the panel peak power at STC ( $W_p$ ) should be **50%** more than the maximum required input power of the motor (motor consumption).

## 6. PRE-SUPPLY TESTING & INSPECTION:

The firm applying for the tender must have test bed facility to carry out pump performance acceptance test witnessed by third party inspector/Client as per ISO-9906 standard. Each of the offered pump set models must undergo this witness test prior to supply and installation.

## 7. DC CABLE / WIRING:

99% copper wires of size at least 6 mm for single and 6 mm or above for multi strings and rated current 30A to be used. Working temperature range should be in between -40C to +85C. The cable must have double insulation suitable for 1000 VDC transmission, and all the relevant test reports i.e.

- Conductor resistance test.
- Insulation resistance test.
- Pressure test.
- Spark test.

Are to be provided in the technical proposal. The wiring must be protected by PVC conduits for underground installations. DC circuit breakers (not fuse) of at least 800V and suitable ampere rating must be installed between PV modules and PV pump controller in order to avoid short-circuiting. No direct jointing in DC power line is allowed, junction boxes of at least IP-44 rating are to be used for easy debugging where necessary. The cable should have safety level class II and standard flame class. Shell protection degree should be IP67 with connector rating IP67 (plug and play). The insertion and withdrawal force up to 50N can be bearable by the cable.

The Supplier should provide the manufacturer quality tests certificates at the time of supply.

## SPECIFICATIONS FOR PUMPING MACHINERY AS PER ISO-9906 STANDARD

### 1. PUMP:

Pumps are to be supplied having standard ISO-9906 specifications. The pump must be submersible, made of stainless steel. The characteristic curves showing the efficiency and performance of the pumps are to be provided in the technical proposals. The quoted pump is to be tested for its performance and certified as per ISO-9906 standard. The pump must be suitable for installation and operation in tube wells/dug wells/open well with clear water discharge. Pump shall comprise of bowl assembly and non-return valve as integral part of pump's parts. Pump and motor shall rigidly couple through NEMA standard coupling. The stage casings of pumps should be connected as per NEMA/ANSI/AWWA/ASTM/BSS standard. Each stage casing must have replaceable wear ring. The impellers shall be secured to the pump shaft with tapered conical sleeves pressed into the taper bore of impeller or impeller secured through chrome plated stainless steel hexagonal sleeves. Suction casing must be between pump and motor with suction strainer as protection of pump against coarse impurities of the liquid handled.

Specification for Main Components of the Pumps:

- 1.1 **CASING/DIFFUSER:** The Casing/Diffuser should be in fabricated stainless steel AISI 304.
- 1.2 **IMPELLERS:** stainless steel AISI 304
- 1.3 **DRIVING SHAFT:** Stainless steel 304/420
- 1.4 **SLEEVES:** Stainless steel AISI 329/ 304
- 1.5 **GASKETS:** Rubber Gaskets
- 1.6 **BEARINGS:** AISI 329 stainless steel
- 1.7 **COUPLING & SCREEN + CABLE GUARD:** Stainless steel AISI 316/319/304/420

- 
- 1.8 **NON-RETURN VALVE:** As per British standard specifications (BSS), Minimum 16 bar pressure sustaining design
  - 1.9 **PRESSURE GAUGE:** As per British standard specifications (BSS), having PSI or Bar scale
  - 1.10 **CLAMPS:** Steel – Pressed
  - 1.11 **PUMP EFFICIENCY:** Minimum efficiency of the pump should be 70% at duty point

## 2. MOTOR:

The origin, make and material of the motor should be clearly mentioned in the technical proposal. The winding material should be 99.99% copper. The motor should have wet type, water cool rewind-able/repairable stator. The motor should have non-disposable/non-hermetically sealed winding. The insulation class of the winding material should be mentioned. For each model quoted, all the technical parameters such as rated voltage, power factor, efficiency, full load ampere, speed and other similar parameters should be provided in the technical proposal. The testing report with all basic parameters should also be provided at the time of supply.

The motor shall be manufactured in compliance with National Electrical Manufacturer Association (NEMA) standards. The motor shall be three-phase submersible and shall be capable of operating at rated voltage of 380 Volts at 50 Hz. The motor should be capable of operating with variable speed through V/F control. Winding of the motor shall of rewind able type with class – IC40 insulation and IP68 protection. The synchronous speed should be 2850-2950 RPM. Motor shall be capable of operating in well water with temperature starting from 40C. Motor should be designed for continuous operation. Motor must be filled with water without any chemical additives hazardous to health, for cooling. The motor must be properly protected against the entry of well water sand etc. by double mechanical seal i.e. one rotating and other stationary and the seal must be made of Silicon carbide/ Tungsten carbide and must be protected with sand protection guards. All supports shall be high grade cast iron and stator outer side jacket body should be in stainless steel in AISI 304. The excessive pressure due to heating up of the filled water must be compensated by a pressure equalizing rubber diaphragm in the lower part of the motor. The axial thrust of the pump shall be countered by oscillating sliding block type thrust bearing. The thrust bearing of the motor should be able to bear a download thrust force from the water pump and the upward thrust force produced while starting the water pump. Motor shall be capable of minimum of 20 starts in an hour. Motor efficiency should not be less than 70%.

Material/technical specifications of rewind-able wet stators, three phase squirrel cage water filled submersible motor.

- 2.1 **WINDING:** Made of pure electrolyte copper a non-hygroscopic poly vinyl chloride for normal temperature and must full fill resistant tests range.
- 2.2 **STATOR:** Energy efficient low-losses electrical magnetic sheet should be fixed in stainless steel casing. M800 or M600 magnetic sheet are preferable to use.
- 2.3 **ROTOR:** Energy efficient low-losses electrical magnetic sheet fixed with high grade copper bars. M800 or M600 magnetic sheets are preferable to use.
- 2.4 **SPLINE SHAFT:** AISI 420 stainless steel, flange dimension according to NEAM standard, over size design to ensure stiffness n severs condition.
- 2.5 **SHAFT BEARING:** Water lubricated guide/general bearings fixed in upper and lower brackets should be made of metal impregnated carbon.
- 2.6 **LOWER THRUST BEARING:** Thrust sliding block bearings, self-aligning Mitchell type, should be able withstand 15500N/20000N axial load.
- 2.7 **MECHANICAL SEAL (STATIONARY & ROTARY):** Silicon carbide or tungsten carbide mechanical seal.
- 2.8 **COOLINGFILLING FLUID:** Water mixed with non-toxic anti-freeze provides cooling and lubrication also protect and prevent inside parts from corrosion.
- 2.9 **DEGREE OF PROTECTION:** IP68
- 2.10 **INSULATION OF CLASS:** Class B.
- 2.11 **VOLTAGE TOLERANCE:** -6% to -10%
- 2.12 **MOUNTING POSITION:** Vertical horizontal
- 2.13 **Class:** IC40
- 2.14 **MAXIMUM IMMERSION:** 150 Meters

**2.15 STATING PER HOUR: 20**

**3. SUBMERSIBLE FLAT ELECTRIC CABLE:**

The submersible cable should be made of 99% copper coated with double PVC, should be adequately flexible and environment friendly. The cable must have undergone quality tests as per BSS standards. Following lab tests are mandatory.

- Conductor resistance test.
- Insulation resistance test.
- Pressure test.
- Spark test.

Note: The Supplier should provide the manufacturer quality tests certificates at the time of supply.

**4. COLUMN PIPE:**

The column pipe shall be flanged ERW steel pipes confirming to ASTM designation A-53 with a minimum thickness of 3.5 mm and shall be painted with corrosion resistance paint of suitable thickness. Flanges thickness of 20 mm shall have grooves for cable passage. Each column pipe shall be complete with gaskets, bolts/studs, washers and nuts. All nuts, bolts, and washers shall be made of minimum A2 grade stainless steel.

The column pipe shall be supplied in interchangeable section having an approximate length of 10 feet. The flanges should be welded perfectly perpendicular to the axis of the pipe.

FEATURES:

- Manufacturer's pipes should meet international standards like BSEN 10255 &ASTMA 53.
- Dimensional accuracy circularity and plan end cut should be observed,
- Weld strength of pipe and mechanical properties or raw material should be tested as per manufacturing standards.
- Pipes should be NDT tested (Non-destructive – Eddy current)
- Pipes should be tested for hydrostatic pressure as per manufacturing standard.
- Pipes should be gone through straightening process to remove bendiness.

**5. TOP SET:**

Top set shall comprise of Bore covers plate, (covering bore hole completely and securely), installation/suspension clamps, sluice valve, reflex valve, connector and cable jointing material (Cable connection from motor to switching device shall be joint free) pressure gauge and cable ties.

---

# DRAWINGS



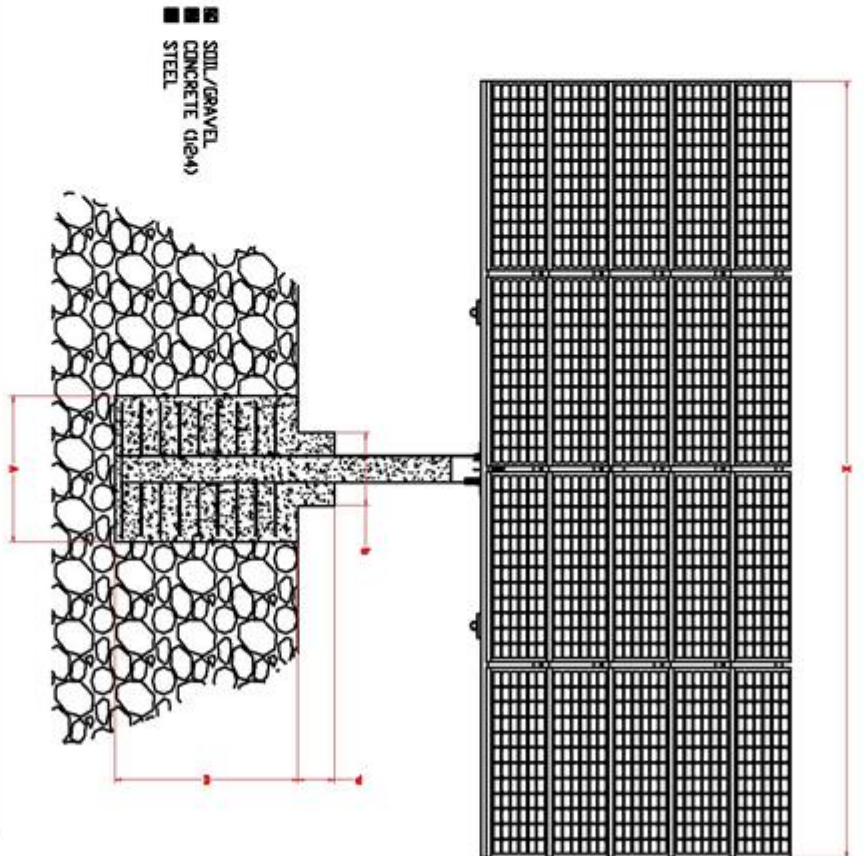
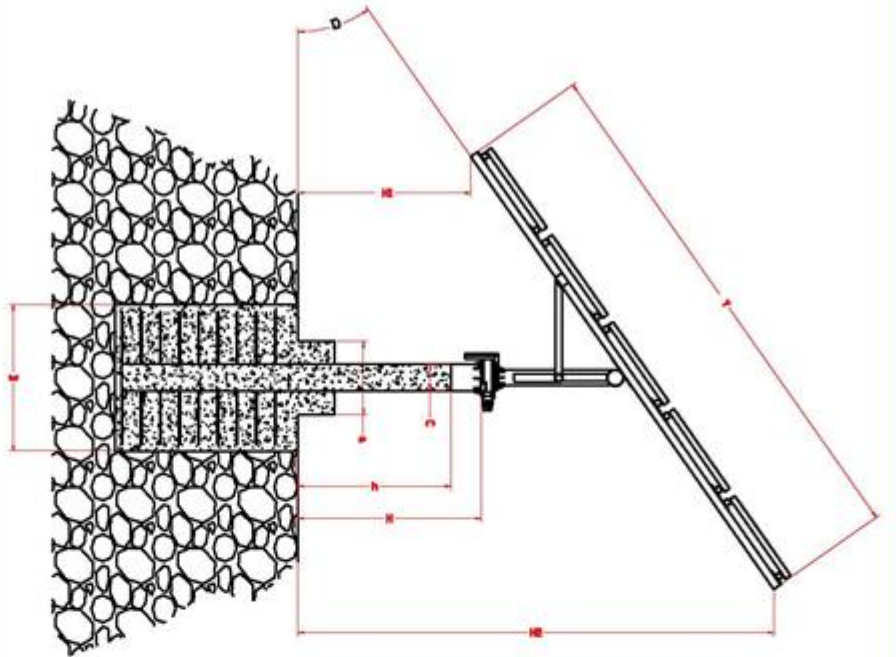

General Dimensions and Concrete Plan of Single Pole PV Mounting Structure with Single Axis Tracking System

Sr. No.	Type/Size	X (ft)	Y (ft)	H1 (ft)	H2 (ft)	a	A (ft)	B (ft)	B (ft)	a (ft)	b (ft)	d (ft)	C (ft)	H (ft)	h (ft)
1	5/72x20	20.7	13.25	>3	12	30-36	4	4	5.5	2	2	1	8	4.5	4
2	5/72x21	18.5	15.55	>3	12	30-36	4	4	5.5	2	2	1	8	4.5	4
3	6/60x18	19.52	16.10	>3	12	30-36	4	4	5.5	2	2	1	8	4.5	4
4	6/60x20	21.5	16.27	>3	12	30-36	4	4	5.5	2	2	1	8	4.5	4

### HOURGLASS WORM SLEWING DRIVE

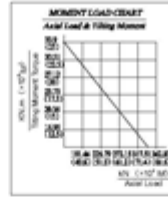
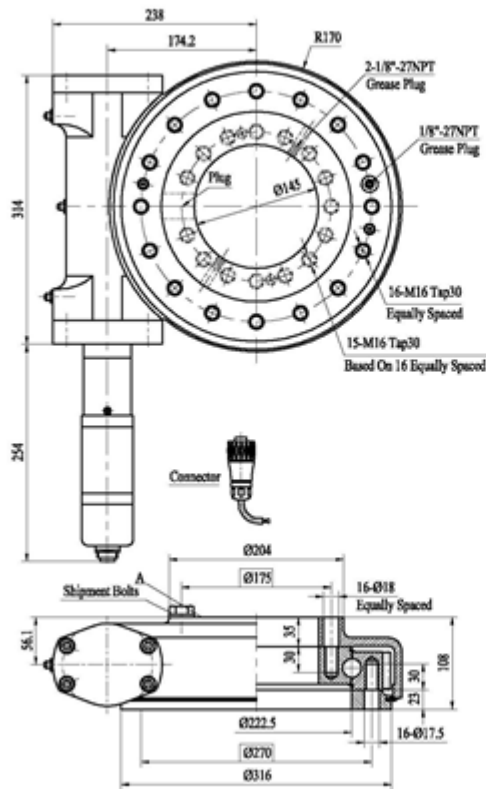

Slewing Drive Performance Data		
Rated Output Speed	0.040 rpm	
Rated Output Torque	696.2 kN.m	696.8 Bt.f
Tilting Moment Torque (Max.)	33.9 kN.m	25+10' Bt.f
Holding Torque	38.7 kN.m	29+10' Bt.f
Axial Load (Max.)	338 kN	76+10' Bt
Radial Load (Max.)	135 kN	30+10' Bt
Ratio of Worm Gear	81:1	
Tracking Precision	± 0.12"	
24VDC Planetary Reducer Motor Performance Data (24093031)		
Rated Voltage	24 VDC	
Rated Current	< 1.2 A	
Gear Ratio	575:1	
Noise	90 dB	
IP Class	IP54	
Temperature	-40 ~ +80C	



- Wire Define:
- Pin 1 motor-
  - Pin 2 motor-
  - Pin 3 hall GND
  - Pin 4 hall+ 12V
  - Pin 5 hall A
  - Pin 6 hall B
  - Pin E Ground

MAGNETIC PULSE GENERATOR DATA	
Output type	voltage output
Pulse generator	yes
Output signal	2 square wave signals
Phase quadrature	90°
Impulses per revolution	ppr 2 channels A and B
Operating voltage	VDC (5V ~ 24V)
Operating current	mA (max. 12 mA @ 12V)
Deviation of pulse width	max. 1%
Deviation of phase shift	max. 1%
Output voltage (low level)	VDC (max. 0.4 (25mA))
Signal rise time	ns (85)
Signal decay time	ns (150)
Operation temperature	°C (-40 ~ +85)

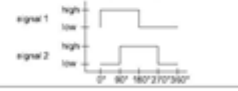

Note: Side A facing up when mounted.